



We create chemistry



Climate and temperature change effect on FRC performance in flexural strength

Trainee: Eng. Edoardo Carbonetti

Relator: Dr. Paolo Colombo

Supervisor: Dr. Sandro Moro, Abdou Kandalajt

Treviso 05-07-2019

Index

Abstract	5
1 INTRODUCTION BASF	7
1.1 CONCRETE MATERIAL	9
1.2 ADDITIVES	15
1.3 WORKABILITY TEST	17
1.4 FRC CONCRETE	19
1.5 MASTERFIBER 246	22
1.6 TEST AND DESIGN METHOD	23
1.7 TOOLS	25
2 PRIORITY n.1	33
2.1 SAMPLE MAKING	34
2.2 SAMPLE TESTING	41
3 PRIORITY n.2	43
3.1 READYMIX	43
3.2 PRECAST	47
4 Pullout Test	49
4.1 SAMPLE MAKING	51
4.2 SAMPLE TESTING	58
5 RESULTS	61
5.1 PRIORITY n.1	61
5.2 PRIORITY n.2	69
5.2.1 READYMIX	69
5.2.2 PRECAST	75
5.3 PULLOUT	83
5.3.1 MORTAR MATURATION OF 7 DAYS	83
5.3.2 MORTAR MATURATION OF 28 DAYS	91
Bibliography	100

Table of Contents

Figure 1 BASF head quarter in Treviso.....	8
Figure 2 Italcementi cement bags.....	10
Figure 3 Hydration process in three phases.....	13
Figure 4 Hydration of aluminates.....	13
Figure 5 Changing of phases before and after cement hydration.....	14
Figure 6 Different concrete additives.....	16
Figure 7 usage of Abram’s cone.....	17
Figure 8 Different types of FRC concrete.....	20
Figure 9 Different types of fibres used in FRC concrete.....	20
Figure 10 Two examples of textile fiber use for concrete flooring and wall.....	21
Figure 11 Close visual of two geometries of fibers used in this experiment: on the left crimping and on the right embossing.....	22
Figure 12 PP pellets used for the extruder.....	25
Figure 13 Extruder used in the experiment.....	26
Figure 14 Production line of PP filament.....	26
Figure 15 From above: extruder die (final part of the extrusion process), rolling process of the filament after the extrusion, particular of the rolls.....	27
Figure 16 Particular of the filament coming out from the oven were hot temperature and continuous stretching force applied give the right diameter.....	28
Figure 17 Particular of the filament passing throw two rolls that give the geometry to the surface.....	29
Figure 18 Machinery used for cutting filament operation.....	29
Figure 19 Setting for pullout test.....	31
Figure 20 Automatic mortar mixer.....	32
Figure 21 First stage of preparation FRC concrete before mixing.....	39
Figure 22 First stage of preparation FRC concrete after mixing.....	40
Figure 23 Pouring phase after mixing.....	40
Figure 24 Setting of Instron machinery with three points flexion. Particular of the sensor under the sample.....	42
Figure 25 Image of the software of Instron machinery.....	42
Figure 26 Setting of pullout test with the software used and the clamp system for samples.....	49
Figure 27 Image of the additive MasterGlenium ACE 440 used for mortar and the cement sample.....	52
Figure 28 Mortar mix before mixing.....	53
Figure 29 Mortar mix after mixing.....	53
Figure 30 Exemple of a sample with the fiber attached on the top ready to be filled with mortar.....	54
Figure 31 Steps of preparation for pullout test samples.....	55
Figure 32 Setting of pullout test on Instron machine.....	58
Figure 33 Closer look to setting of the clamp in pullout test.....	59

Figure 34 View of fibers on surface of cracked samples..... 67

Figure 35 Set of tested samples after final cracking..... 67

Figure 36 particular of fibers: some are completely frayed/ exhausted, others are still intact due to different behaviour during flexural test..... 68

Abstract

This study wants to determine the influence of moderate temperatures on physical and mechanical properties of polypropylene fibers and their adhesion to cement matrix of mortars and concretes. Different experimental fibers with different geometries but same mechanical properties are produced and tested in order to understand if different dimensional parameters are influenced by increasing temperature from 20°C to 50°C simulating the exposition of an elevated solar radiation structure in typical summer climax.

From the beginning part of the polypropylene fibers have been produced by extrusion and part where already available in bags. The production took about three weeks considering the time used to produce the filament, to give the geometry (crimping or embossing) and to cut in different lengths (30mm or 50mm).

For priority n.1 the concrete mix was based on the normal amount of cement, cv and others while for the fibers we used the DOE method to better understand the behavior of the mix depending on different parameters for the fibers.

For priority n.2 the concrete mix was of two different type called Ready-mix and Precast which differentiate mostly from dosage of the fibers (4.5 Kg/m³ or 9 Kg/m³). The samples have been tested in different scenarios where parameters like temperature, humidity and additives were compared from a maximum value to a minimum one. Also, a CMOD samples were tested to ensure the influence of two different temperatures on pre-cracked concrete.

In this study an important part was dedicated to pullout test which provides information about maximum strength to pull a single fiber out from a sample of mortar. These tests were performed with three different types of fiber diameter at room temperature and 50 or 90 degrees.

1 INTRODUCTION BASF

BASF CC is a German chemical company and the largest chemical producer in the world. The BASF Group comprises subsidiaries and joint ventures in more than 80 countries and operates six integrated production sites with 390 other head-quarters all around the world. Its headquarters is located in Ludwigshafen, Germany. BASF has customers in over 190 countries and supplies products to a wide variety of industries. Despite its size and global presence, BASF has received relatively little public attention since it abandoned manufacturing and selling BASF-branded consumer electronics products in the 1990s.

BASF (stands for Badische Anilin und Soda Fabrik, German for "Baden Aniline and Soda Factory") was founded by Friedrich Engelhorn on 6 April 1865 in Mannheim. Engelhorn had been responsible for setting up a gas-works and street lighting for the town in 1861. The gas-works produced tar as a by-product, and Engelhorn used this for production of colouring liquids. BASF was set up in 1865 to produce other chemicals necessary for dye production, like soda and acids. The plant, however, was erected on the other side of the Rhine river at Ludwigshafen, because the town of Mannheim was afraid that the air pollution from the chemical plant could bother the inhabitants of the town. In 1866, the dye production processes were also moved to the BASF site.^[8]

BASF operates in a variety of markets and its business is organized in the segments of chemicals, plastics, performance products, functional solutions, agricultural solutions and Oil & Gas.

BASF's recent success is characterized by a focus on creating efficient product lines after completely abandoning consumer products. This strategy was reflected in production by a re-focus towards integrated production sites. The largest such integrated production site is located in Ludwigshafen employing 33,000 people.

Integrated production sites are characterized by co-location of a large number of individual production lines (producing a specific chemical), which share an interconnected material flow. Piping is used ubiquitously for volume materials. All production lines use common raw material sourcing and feedback waste resources, which can be used elsewhere (e.g. steam of various temperatures, sulfuric acid, carbon monoxide). The economic incentive for this approach is high resource and energy efficiency of the overall process, reduced shipping cost and associated reduced risk of accidents. Due to the high cost of such an integrated production site, it establishes a high entry barrier for competitors trying to enter the market for volume chemicals.



Figure 1 BASF head quarter in Treviso

Many innovations were born on the site of Treviso, in particular in the field of superplasticizers that make the concrete product more compact and more resistant to pollutants. Headquarters of BASF Construction Chemicals, the Treviso plant produces and markets materials for the construction industry: cement and concrete additives, polymers and powder products.

BASF Construction Chemicals also operates in Latina, where in 2007 it opened the latest new plant for the production of powdered products. At the Treviso site there is an important Research and Development center.

1.1 CONCRETE MATERIAL

Concrete is a composite material made from aggregates of different dimensions, cement, water and other additives that improve the performance and usually reduce the amount of water needed for the mix. Generally the Portland cement concrete is the most used and diffused one, well known for its durability and strength. The aggregates are usually made from rocky materials (gravel) with diameter from the sand type to 2 cm. Their provenience is from coarse gravel or crushed rocks as limestone or granite. The sand aggregates are mostly composed by silica. The Portland cement is the most common binder of this mixture and has an important role in the hydration process. Some mineral powder can be added such as fly ash, coming from coal-fired power plants, silica fume, an ultrafine powder collected by ferrosilicon alloy implants, and slag, residual waste of ironmaking process. During the mixing process water is added to the powder cement and all the others aggregates and the result is a semiliquid slurry that is generally poured into some steel forms and left maturing for at least three weeks. Most of the times to the mix are added different kind of additives to improve the overall mechanical performance and to reduce the amount of water. The workability is a fundamental property of the concrete mix because it allows the compound to fill any type of form properly (sometimes requiring vibration for difficult shapes like sharp edges). This property depends strictly on the amount of water: if the mix is excessively watery there is risk of segregation of aggregates and bad performing concrete; on the other side an excessive dry mix leads to low workability. Generally speaking, the amount of water depends on the performance needed and must ensure a low porosity of the cement matrix.

Portland cement is the main ingredient of concrete and mortars, patented originally in 1824 is composed by calcium silicates, aluminates and ferrites that are particularly inclined to react with water. Industrial cement is produced by heating limestone, calcium silicates and other minerals into cement kilns where the pyro-processing takes place. The final formula of the mix is $\text{Ca}_3\text{O} \cdot \text{SiO}_4$, better known as C3S cement.

PORTLAND CEMENT

Portland cement is a complex product obtained from unprocessed common natural materials: limestone and clay. Consequently, the characteristics of Portland cement clinker may vary from one cement plant to another. To limit the variations of the technological properties of Portland cement, acceptance standards have been developed, but presently these standards are not satisfactory for the whole concrete market. Low w/c cements are increasingly used; these concretes are made using large dosage of superplasticizers to disperse cement particles. It is therefore urgent for the cement industry to produce a clinker that will facilitate the production of the low w/c concretes that are more sustainable than normal-strength concretes. The production of the old Type I/II clinker must continue to satisfy the needs of this very profitable market, because now that we know how to increase concrete compressive strength, it is very important that we focus on how to improve the rheology of these concretes in order to transform concrete into a quasi-liquid material that can be poured without any problem. The chemical constituents of Portland cement are as follows:

Lime (CaO)	60 to 67%
Silica (SiO ₂)	17 to 25%
Alumina (Al ₂ O ₃)	3 to 8%
Iron oxide (Fe ₂ O ₃)	0.5 to 6%
Magnesia (MgO)	0.1 to 4%
Sulphur trioxide (SO ₃)	1 to 3%
Soda and/or Potash (Na ₂ O+K ₂ O)	0.5 to 1.3%



Figure 2 Italcementi cement bags

Classification by characteristics and applications:

Type I

- General purpose
- Fairly high C_3S content for good early strength development
- General construction (most buildings, bridges, pavements, precast units, etc)

Type II

- Moderate sulfate resistance
- Low C_3A content (<8%)
- Structures exposed to soil or water containing sulfate ions

Type III

- High early strength
- Ground more finely, may have slightly more C_3S
- Rapid construction, cold weather concreting

Type IV

- Low heat of hydration (slow reacting)
- Low content of C_3S (<50%) and C_3A
- Massive structures such as dams. Now rare.

Type V

- High sulfate resistance
- Very low C_3A content (<5%)
- Structures exposed to high levels of sulfate ions

White

- White color
- No C_4AF , low MgO
- Decorative (otherwise has properties similar to Type I)

CONCRETE HYDRATION

By the process of hydration (reaction with water) Portland cement mixed with sand, gravel and water produces the synthetic rock we call concrete. Clinker is anhydrous (without water) having come from a hot kiln. Cement powder is also anhydrous if we ignore the small amount of water in any gypsum added at the clinker grinding stage. The reaction with water is termed "hydration". This involves many different reactions, often occurring at the same time. As the reactions proceed, the products of the hydration process gradually bond together the individual sand and gravel particles, and other components of the concrete, to form a solid mass.

The hydration of cement can be thought of as a two-step process. In the first step, called dissolution, the cement dissolves, releasing ions into the mix water. The mix water is thus no longer pure H₂O, but an aqueous solution containing a variety of ionic species, called the pore solution. The gypsum and the cement minerals C₃S and C₃A are all highly soluble, meaning that they dissolve quickly. Therefore, the concentrations of ionic species in the pore solution increase rapidly as soon as the cement and water are combined. The second step of the hydration process is called precipitation. A key point, of course, is that these new precipitated solid phases, called hydration products, are different from the starting cement minerals. Precipitation relieves the supersaturation of the pore solution and allows dissolution of the cement minerals to continue. Thus, cement hydration is a continuous process by which the cement minerals are replaced by new hydration products, with the pore solution acting as a necessary transition zone between the two solid states. The reactions between Portland cement and water have been studied for more than a hundred years, and the fact that hydration proceeds by a dissolution-precipitation process was first elaborated by the famous chemist Le Chatelier.

The reactions that take place during hydration are the followings:

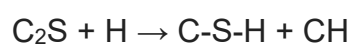
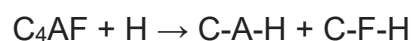
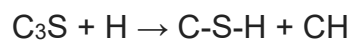
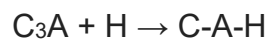

The presence of C-S-H (calcium-silicates-hydrated) is responsible of the hardening effect while C-A-H (calcium-aluminate-hydrated) formation reduces workability.

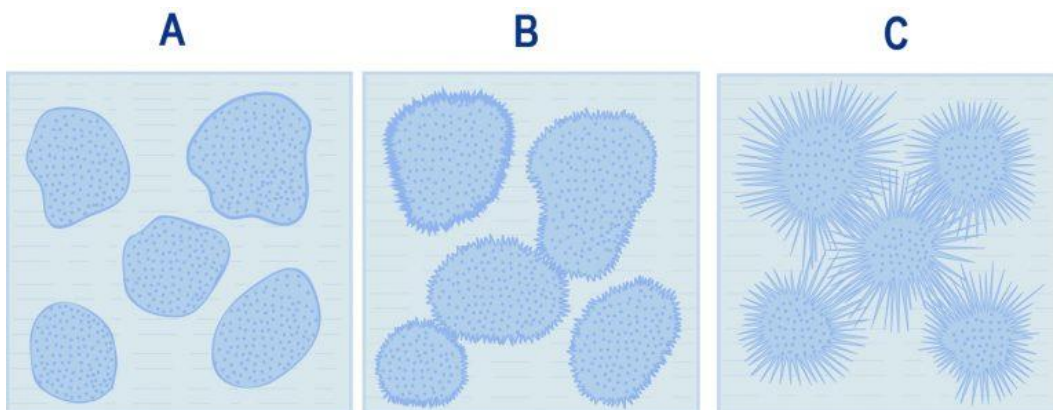
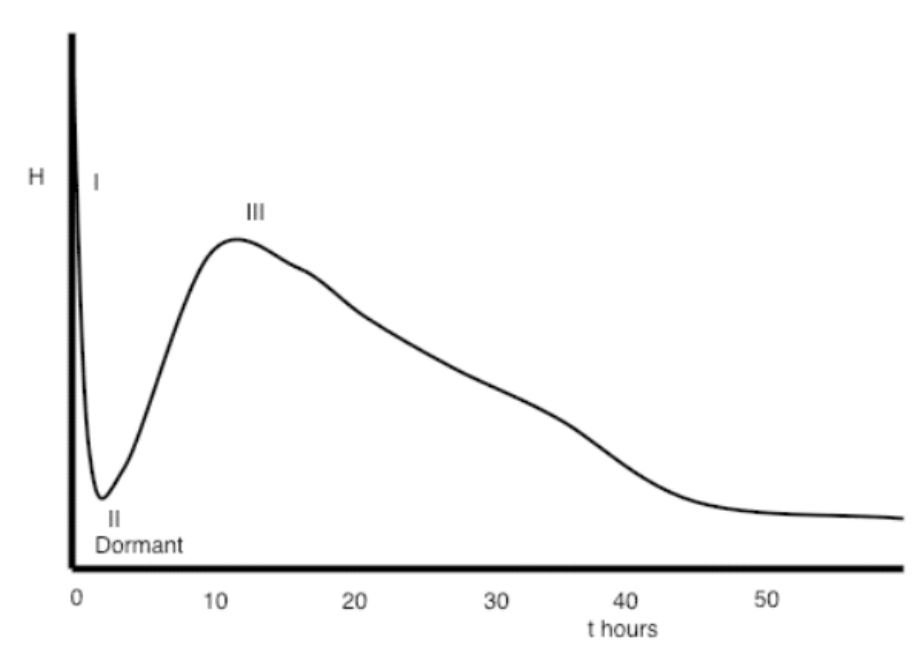

Figure 3 Hydration process in three phases

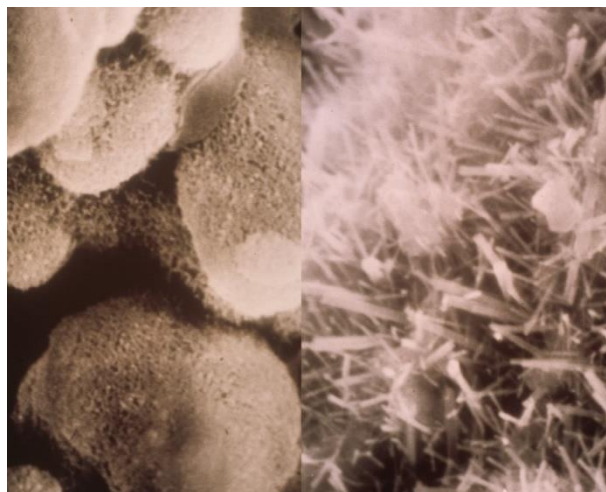

Figure 4 Hydration of aluminates

The overall progress of the hydration reactions is described by the degree of hydration which is simply the fraction of the cement that has reacted. Complete hydration of all the cement gives $= 1$. The degree of hydration can be measured in a few different ways, including x-ray measurements to determine how much of the minerals remain and loss on ignition measurements to determine how much bound water the paste contains. Another common method is to sum the amount of heat given off by the paste (as measured by thermal calorimetry) and divide this value by the total amount of heat given off for complete hydration. The latter value will depend on the mineral composition of the cement. Another parameter that can be used to monitor the progress of hydration is the compressive strength. This is not a precise measure, since the strength depends on many factors other than the progress of the chemical reactions, but it is very practical since the development of strength is the primary reason for using cement and concrete in the first place.

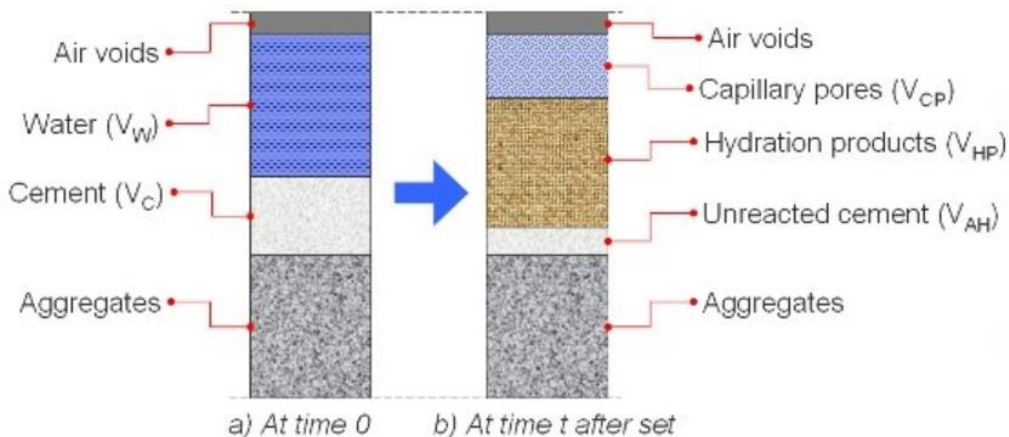
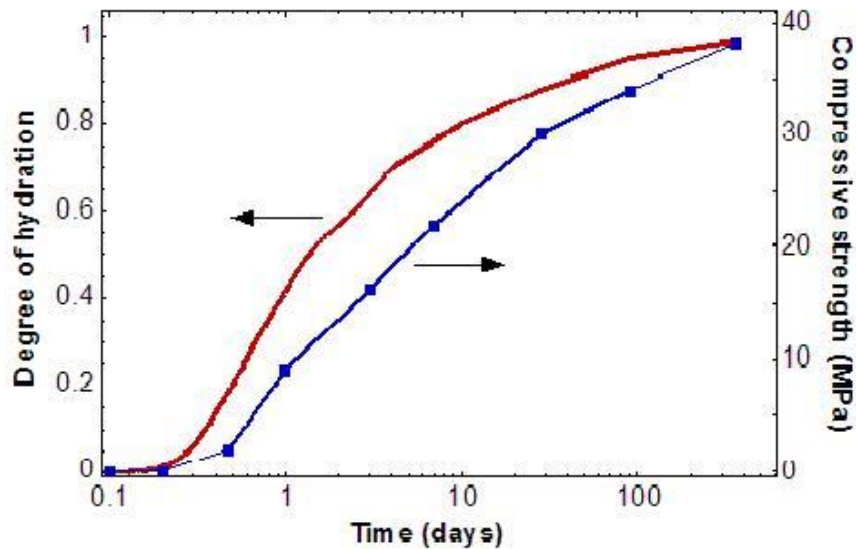

Figure 5 Changing of phases before and after cement hydration

1.2 ADDITIVES

Admixtures are added to concrete batch immediately before or during mixing concrete. Concrete admixtures can improve concrete quality, manageability, acceleration, or retardation of setting time, among other properties that could be altered to get specific results. These are the most common types of additives:

- **Set-Retarding:** are used to delay the chemical reaction that takes place when the concrete starts the setting process. These types of concrete admixtures are commonly used to reduce the effect of high temperatures that could produce a faster initial setting of concrete
- **Air-Entrainment:** Air entrained concrete can increase the freeze-thaw durability of concrete. This type of admixture produces a more workable concrete than non-entrained concrete while reducing bleeding and segregation of fresh concrete. Improved resistance of concrete to severe frost action or freeze/thaw cycles.
- **Water-Reducing:** Water-reducing admixtures are chemical products that when added to concrete can create a desired slump at a lower water-cement ratio than what it is normally designed. Water-reducing admixtures are used to obtain specific concrete strength using lower cement content
- **Accelerating:** Accelerating concrete admixtures are used to increase the rate of concrete strength development or to reduce concrete setting time. Calcium chloride could be named as the most common accelerator component; however, it could promote corrosion activity of steel reinforcement.
- **Shrinkage Reducing:** Shrinkage-reducing concrete admixtures are added to concrete during initial mixing. This type of admixture could reduce early and long-term drying shrinkage. Shrinkage reducing admixtures can be used in situations where shrinkage cracking could lead to durability problems or where large numbers of shrinkage joints are undesirable for economic or technical reasons
- **Superplasticizers:** The main purpose of using superplasticizers is to produce flowing concrete with a high slump in the range of seven to nine inches to be used in heavily reinforced structures and in placements where adequate consolidation by vibration cannot be readily achieved
- **Corrosion-Inhibiting:** Corrosion-inhibiting admixtures fall into the specialty admixture category and are used to slow corrosion of reinforcing steel in concrete. Corrosion inhibitors

can significantly reduce maintenance costs of reinforced concrete structures throughout a typical service life of 30 – 40 years.



Figure 6 Different concrete additives

In these experiments we used the following additives:

- **MasterGlenium SKY 623:** Super-fluidifying admixture based on second-generation polycarboxylates ethers, indicated for the production of ready-mixed concrete with a low A / C ratio and high maintenance of workability. Recommended for winter climates. MasterGlenium SKY 623 has been specifically designed to produce ready-mixed concrete, both rheoplastic (fluid and non-segregable) and Re-dynamic, the evolution of self-compacting concrete, with a low water-to-cement ratio, high maintenance of workability, excellent mechanical strength both for short and long curing periods and durable according to EN 206-1 and UNI 11104.
- **MasterGlenium ACE 440:** ready-to-use liquid that is introduced into the cement mixer after the other components of the concrete have been loaded and mixed. It can be used for the production of prefabricated products with rheoplastic concrete (fluid and non-segregable), workable for the time required for installation, with a low A / C ratio, very high mechanical strength both for short and long curing periods.

1.3 WORKABILITY TEST

Concrete slump test or slump cone test is to determine the workability or consistency of concrete mix prepared at the laboratory or the construction site during the progress of the work. Concrete slump test is carried out from batch to batch to check the uniform quality of concrete during construction. The slump test is the simplest workability test for concrete, involves low cost and provides immediate results. Due to this fact, it has been widely used for workability tests since 1922. The slump is carried out as per procedures mentioned in ASTM C143 in the United States, IS: 1199 – 1959 in India and EN 12350-2 in Europe. Generally concrete slump value is used to find the workability, which indicates water-cement ratio, but there are various factors including properties of materials, mixing methods, dosage, admixtures etc. also affect the concrete slump value.

The test is carried out using a metal mould in the shape of a conical frustum known as a slump cone or Abrams cone, that is open at both ends and has attached handles. The tool typically has an internal diameter of 100 millimetres (3.9 in) at the top and of 200 millimetres (7.9 in) at the bottom with a height of 305 millimetres (12.0 in). The cone is placed on a hard-non-absorbent surface. This cone is filled with fresh concrete in four stages. At the end of the fourth stage, the concrete is struck off flush with the top of the mould. The mould is carefully lifted vertically upwards, so as not to disturb the concrete cone.



Figure 7 usage of Abram's cone

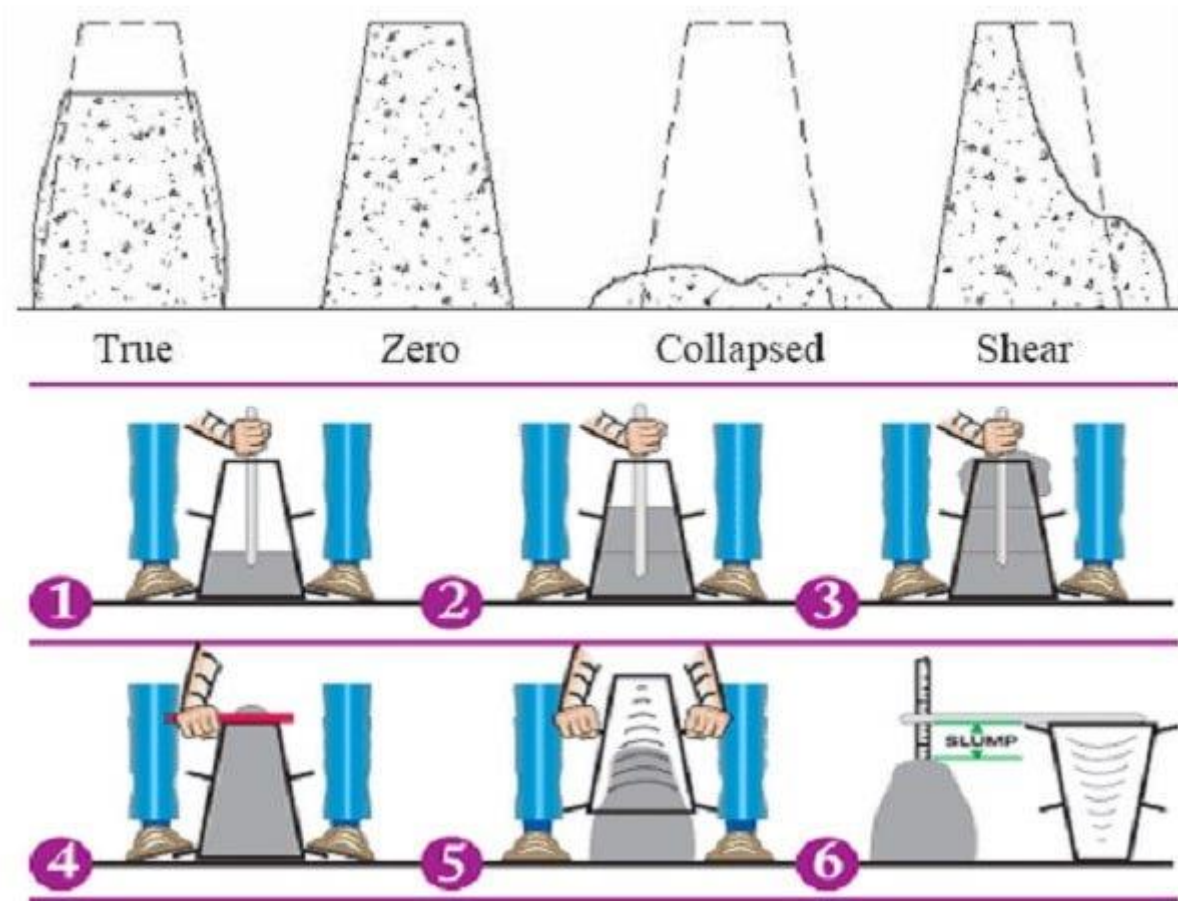

There are three different scenarios:

- True Slump – True slump is the only slump that can be measured in the test. The measurement is taken between the top of the cone and the top of the concrete after the cone has been removed as shown in figure-1.
- Zero Slump – Zero slump is the indication of very low water-cement ratio, which results in dry mixes. These types of concrete are generally used for road construction.
- Collapsed Slump – This is an indication that the water-cement ratio is too high, i.e. concrete mix is too wet or it is a high workability mix, for which a slump test is not appropriate.
- Shear Slump – The shear slump indicates that the result is incomplete, and concrete to be retested.

1.4 FRC CONCRETE

Based on ordinary concrete fiber reinforced concrete is made by evenly scattering the short and fine dispersed fibers into concrete matrix. The purpose of this article is to reduce the brittleness of concrete. There are two kinds of common short-cut fibers: one is the fiber with high elastic modulus, such as steel fiber, glass fiber, and carbon fiber; the other one is the fiber with low elastic modulus, such as nylon fiber, polyethylene fiber and polypropylene fiber. The low modulus fiber can improve toughness but rarely affects the tensile strength; the high modulus fiber can significantly increase the tensile strength. In fiber reinforced concrete, fibers' mixing amount, aspect ratio, distribution and alkali resistance greatly influence its properties. Take steel fiber for example, theoretically, both the bending strength and the tensile strength will rise with the increase of fiber-content ratio. The best aspect ratio of steel fiber is 60 ~ 100. It is usually in straight shape, wave shape, and with hooks on the two ends. In application, it would be better to choose the shape. The steel fiber used in concrete, the strength by more than 2 times, the strength by more than 5 times, even the times by the 100 times above. Recently, fiber reinforced concrete has already been used for roads, bridges, aircraft runways, pipes, roofs, wall panels, and other elevations.

The mechanical behavior of fiber reinforced concrete (FRC) depends largely on the interactions between the fibers and the brittle concrete matrix: physical and chemical adhesion; friction; and mechanical anchorage induced by complex fiber geometry or by deformations or other treatments on the fiber surface. The “first generation” steel fibers, produced by shearing thin sheets of steel, were not very efficient, because they were too smooth to bond well with the matrix. Subsequently, many different fiber geometries (Fig. 7.1) were developed to improve the mechanical anchorage, which is the most important of the bonding mechanisms. Surface treatments of the synthetic (mostly polypropylene) fibers have been similarly employed to improve the fiber-matrix bond.

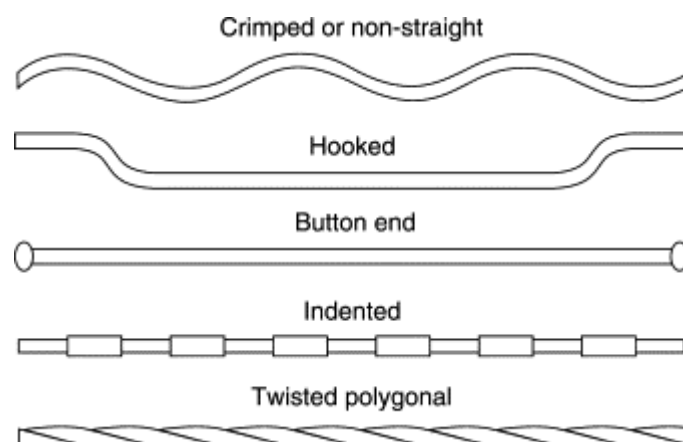

As FRC is stressed (either by external loads or by shrinkage or thermal stresses), there is initially elastic stress transfer between the fibres and the matrix. Because the fibres and the matrix have very different elastic moduli, shear stresses develop at the fibre/matrix interface. When the shear stress at the interface is exceeded, debonding gradually begins to occur, and frictional shear stresses become the dominant stress transfer mechanism. At some point during this gradual transition from elastic to frictional stress transfer, some cracking of the matrix occurs, and some frictional slip occurs in the de-bonded areas.



Figure 8 Different types of FRC concrete

The fibres added to the concrete mix can be made of:

- Steel;
- polymers (nylon, aramid, polyester, acrylic, polyethylene or polypropylene);
- carbon.



Figure 9 Different types of fibres used in FRC concrete

Textile-reinforced concrete using corrosion-resistant reinforcements like alkali-resistant (AR) glass fibers is carbon economically and functionally superior to classical steel-reinforced concrete. Thanks to their excellent material properties, notably the freedom from corrosion but also lightness and flexibility, textile reinforcements have made their entrance into the modern concrete construction market. The advent of textile-reinforced concrete has led to corrosion damage and the high costs associated with the rehabilitation and maintenance of steel-reinforced concrete being a part of the past. Concrete elements can be made thinner, more easily and more efficiently than can easily exceed $3,000 \text{ N / mm}^2$.

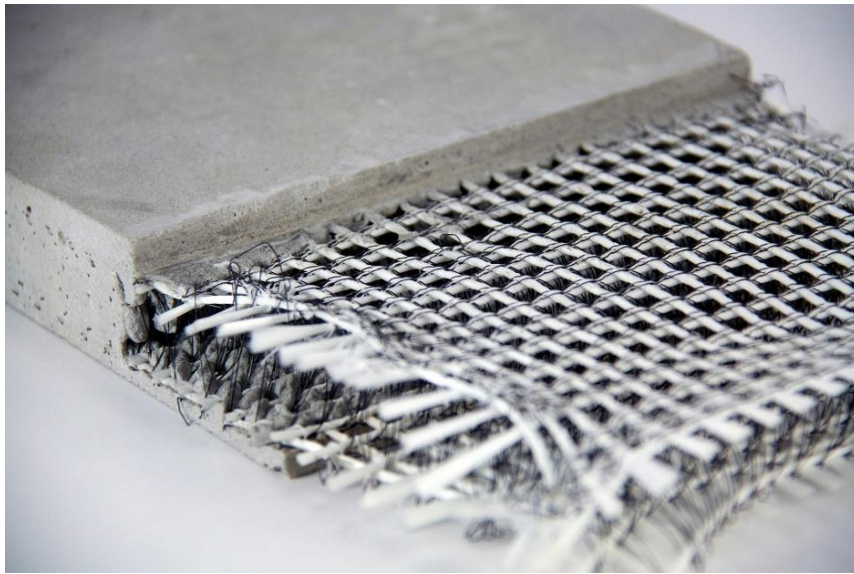

Figure 10 Two examples of textile fiber use for concrete flooring and wall

1.5 MASTERFIBER 246

The MasterFiber 246 synthetic macro fibres must be added to the truck mixer after the mixing water and the additive are introduced, preferably during the loading phase of the aggregates, or in the pre-mixer after all the components have been introduced. At the end of the load it is recommended to mix for at least 5 minutes in order to ensure a good homogenization of the fibres in the cement mixture. MasterFiber 246 is a macro synthetic fibre obtained by extrusion of synthetic polymers based on polypropylene, with a "corrugated" profile, optimized to increase adhesion to the cement matrix of the conglomerate. It allows to reinforce the concrete, increasing its ductility and toughness. This type of fibres are particularly suitable in the conglomerate packaging intended for alkaline environments, where high chemical resistance is required, in aggressive or potentially aggressive environments and in all cement-based systems where a corrosion phenomenon is potentially possible. The MasterFiber 246 synthetic macro fibres have a good dispersibility within the cement mixtures, an essential element for the realization of homogeneous concretes.

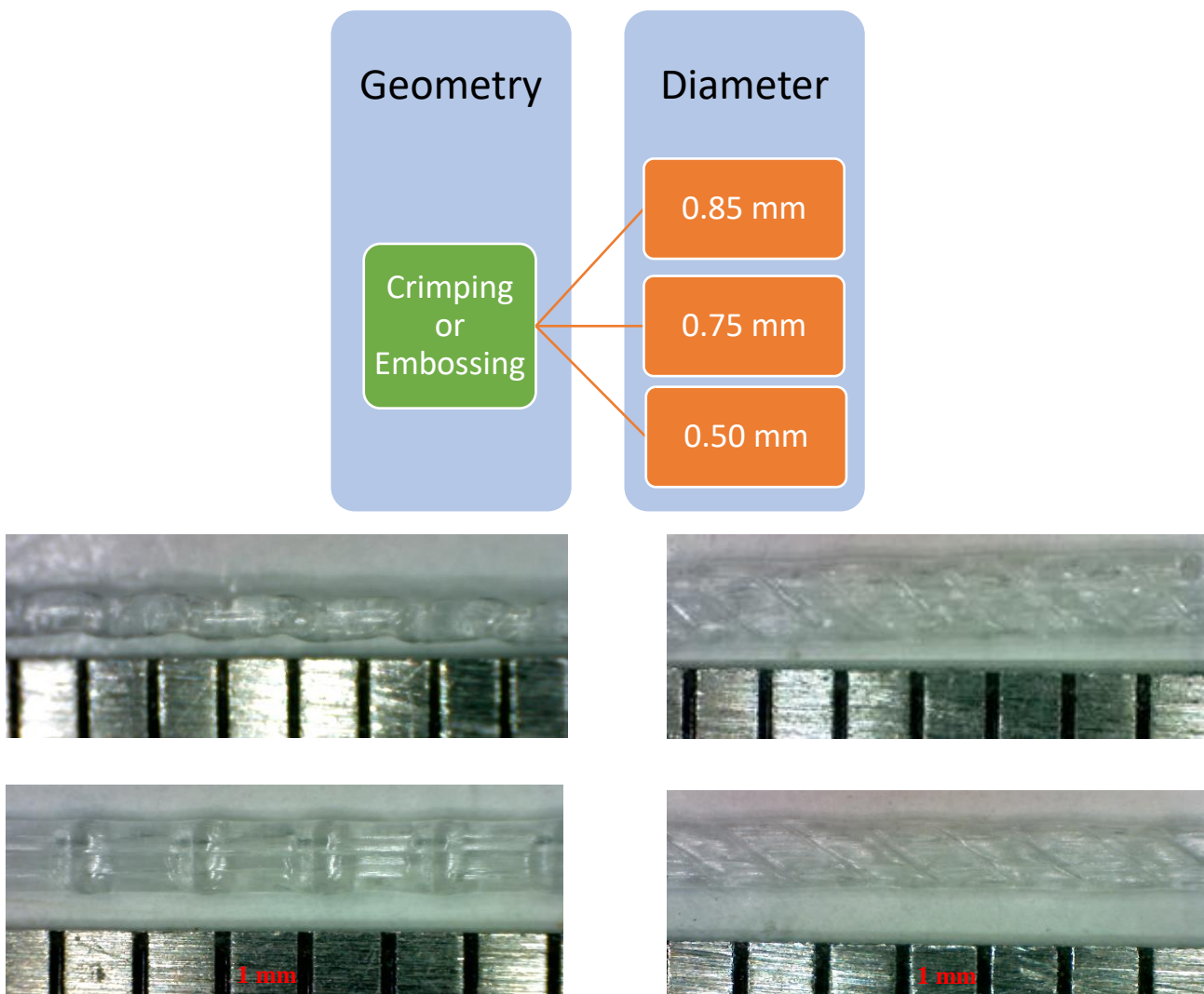

Figure 11 Close visual of two geometries of fibers used in this experiment: on the left crimping and on the right embossing

1.6 TEST AND DESIGN METHOD

This test method evaluates the tensile behavior of steel fiber reinforced concrete either in terms of areas under the load-deflection curve or by the load bearing capacity at a certain deflection or crack mouth opening displacement (CMOD) obtained by testing a simply supported notched beam under three-point loading.

This test method can be used for the determination of:

- the limit of proportionality (LOP), i.e. the stress which corresponds to the point on the load-deflection or load-crack mouth opening displacement curve defined in part 5 as limit of proportionality;
- two equivalent flexural tensile strengths which identify the material behaviour up to the selected deflection. These equivalent flexural tensile strengths are determined according to part 5;
- four residual flexural tensile strengths which identify the material behaviour at a selected deflection or CMOD. The residual flexural tensile strengths are calculated according to procedures in part 5.

Concrete beams of 150 x 150 mm cross section with a minimum length of 550 mm are used as standard test specimens. After mixing all the concrete mix components the mixture should be poured following this scheme:

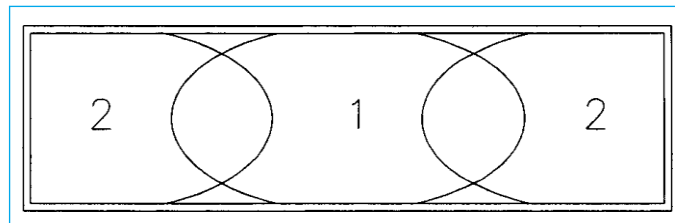

A testing machine which is capable of producing a constant rate of increase of deflection or CMOD of the test specimen, preferably a closed loop machine, should be used. The apparatus measuring deflection should be capable of recording accurately the midspan deflection, excluding extraneous deformations due to deformations of the machine and/or of the specimen supports. Normally deflection is measured at one side of the specimen and the transducer has to be carefully mounted in order to minimize the effect of rotation.

UNI EN 14651

This European Standard specifies a method of measuring the flexural tensile strength of metallic fibered concrete on moulded test specimen. The method provides for the determination of the limit of proportionality (LOP) and of a set of residual flexural tensile strength values.

- CMOD, or crack mouth opening displacement, linear displacement measured by a transducer positioned on the notch made on one surface of the sample;
- LOP, or limit of proportionality, is the stress at the tip of the notch which is assumed to act in an uncracked mid-span section with linear stress distribution;
- To create the notch on the sample surface is used a saw with rotating carborundum or diamond blade with adjustable and fixable cutting depth and 90° direction of saw-cut to the specimen's lengths;

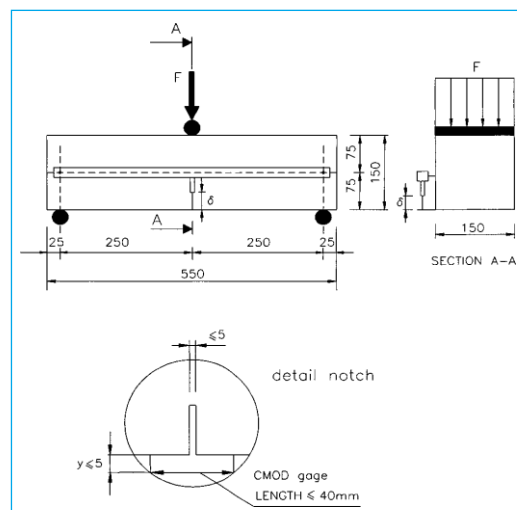
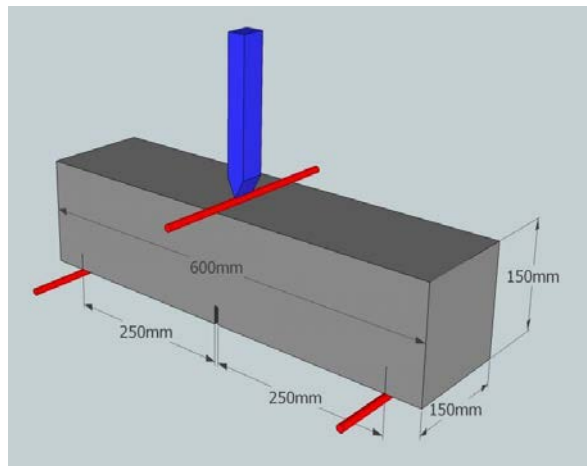

1.7 TOOLS

THE POLYPROPYLENE EXTRUDER

All the fibres used for this experiment have been produced locally with a polypropylene extruder by the 'Melt spinning' process. The raw material was made of pure polypropylene polymer in form of small pellets. The extrusion process was divided in several stages each of them to confer a particular physical property to the filament.



Figure 12 PP pellets used for the extruder

The extruder used is the E 20 T model of the TEACH-LINE® range and it is designed for training and educational purposes. Operated in conjunction with Collin's extensive range of downstream equipment, these lines can be used for studying polymer processing methods on a small scale. Due to its versatility, it is also suitable for processing polymer material at very small throughput rates as required for research and development applications.

Both the electric drive components and the control system are integrated into the machine's substructure. An ergonomically inclined operator panel with a logical design provides easy access to operating buttons and displays. The drive and processing unit is mounted on the machine substructure. The thrust bearing assembly and the barrel are installed on the A.C. gear motor.

The barrel and the screw are made from nitride steel. Collin supplies a wide range of screws for processing all established thermoplastics and elastomers. The barrel is heated by three heating zones, two of which operate with air cooling. A quick-release hopper facilitates material changes and cleaning. The unit is equipped with a water-cooled feed section.



Figure 13 Extruder used in the experiment



Figure 14 Production line of PP filament

First stage is the moulding process: the pellets are inserted from the top into the feed hopper and pulled by the turning screw towards the die. In this phase the solid PP pellets are heated by heaters and thermocouples at 210°C and melted. The particular form of the screw ensures the perfect mixing of the mould and gives the required pressure to the polymer exiting from the die.

The filament coming out from the extruder is then passed into a water basin to lower the temperature; the water is about 20°C (ambient temperature) while the filament still maintains the moulding temperature of about 200°C . After that the polymer diameter is being reduced by passing through several rollers which stretch the filament.

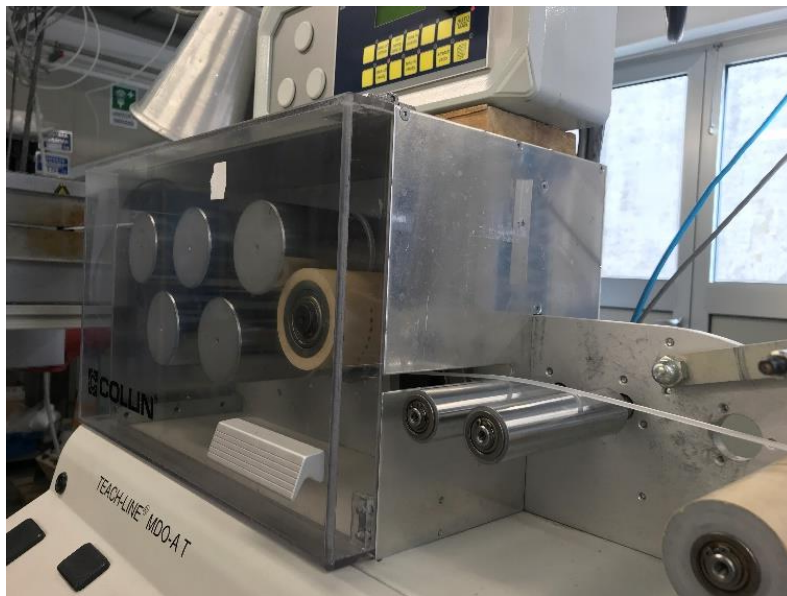
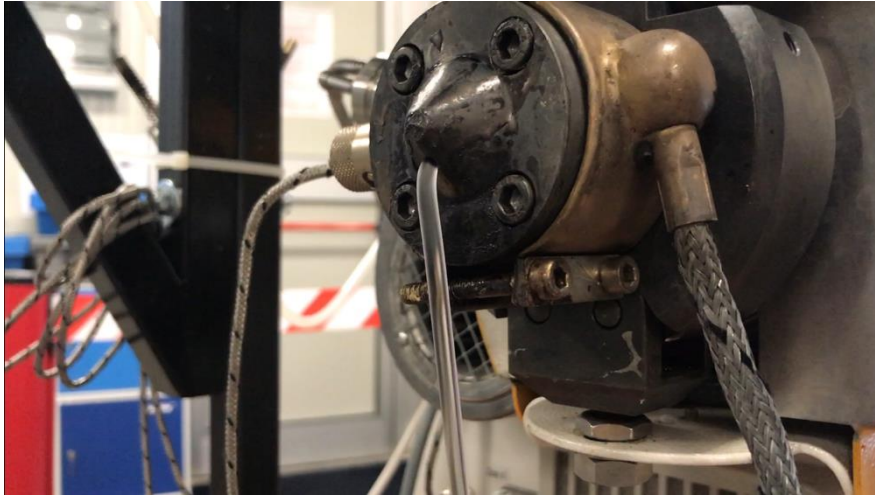

Figure 15 From above: extruder die (final part of the extrusion process), rolling process of the filament after the extrusion, particular of the rolls

After the first stretch the filament is passed into an oven at 220°C to partially melt the polymer to the viscoelastic point. The continuous stretch applied to the filament gives the shrinkage of the diameter needed to reach the nominal value.



Figure 16 Particular of the filament coming out from the oven where hot temperature and continuous stretching force applied give the right diameter

After the thermal stretch another shrinkage process takes place with the passage of the filament through several rollers and finally it is wrapped in a bobbin.

The geometry that has been used to study the clinging effect of the fibre to the cement matrix was given to the filament in a cold working condition: from the clew the polymer has been pulled through a couple of rollers which plastically deform the filament in the two different geometries called *crimping* or *embossing*.



Figure 17 Particular of the filament passing through two rolls that give the geometry to the surface

The final stage is that of the cut where the filament is pulled and divided into singular fibres with two different lengths of 30mm or 50mm.



Figure 18 Machinery used for cutting filament operation

INSTRON MACHINE FLEXURAL TEST

For the flexural strength test, we used an Instron machine model 5582 which is composed by a frame base, containing the mechanical and electrical components that power the machine, on which is fixed a steel base beam with two brackets supporting the sample during the test. The brackets can be modified and moved towards the beam to adapt the machine to the specific test needed. On both sides of the beam there are two screw columns connected to the frame base supported by guides on which slides up and down the top plate that includes in the centre a bracket whom transfers the force to the sample. A control panel is attached to one of the columns and it includes several functions of the machine such as to raise up or lower the top plate and emergency stop button.

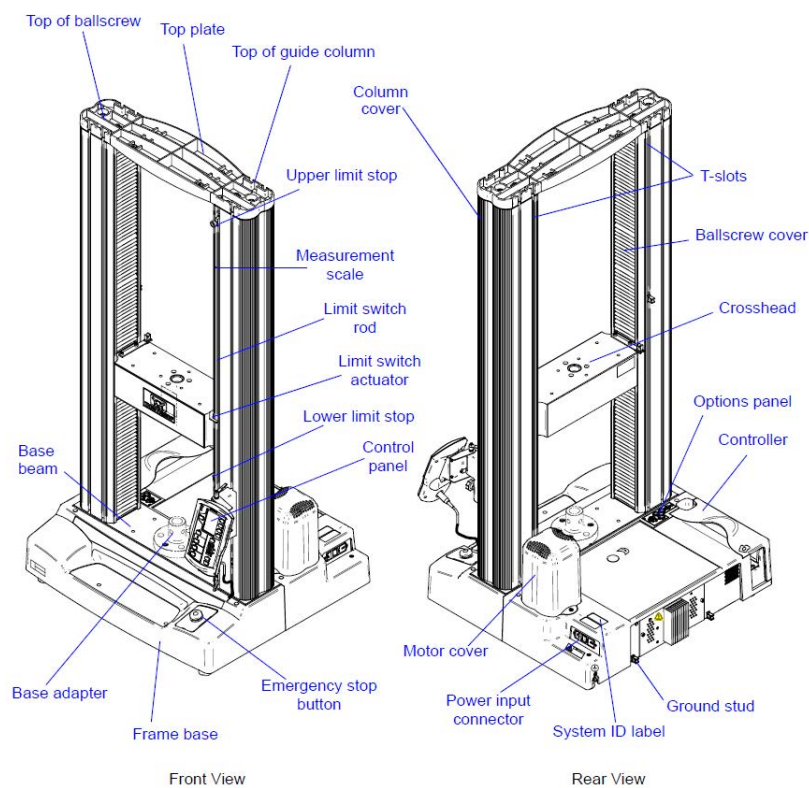

The software is capable of modifying all the parameters of the test including opening speed of the sensor positioned underneath the sample and to obtain the major precision from the measurement it is possible to insert all the dimensions of the sample and of the cut edge (notch).

INSTRON MACHINE PULLOUT TEST

For the pull-out test we used an Instron machine model 3344 composed by a frame base containing the mechanical and electrical components that power the machine and a vertical beam where a mechanism bears a clamp and can move up or down. The clamp is changeable depending on the test that has to be done. A simple control panel allows the operator to move the clamp and to eventually stop the machine in case of danger. For our test we measured the tensile strength needed to pull out a single polypropylene fibre inserted into a mortar sample for 10 mm.

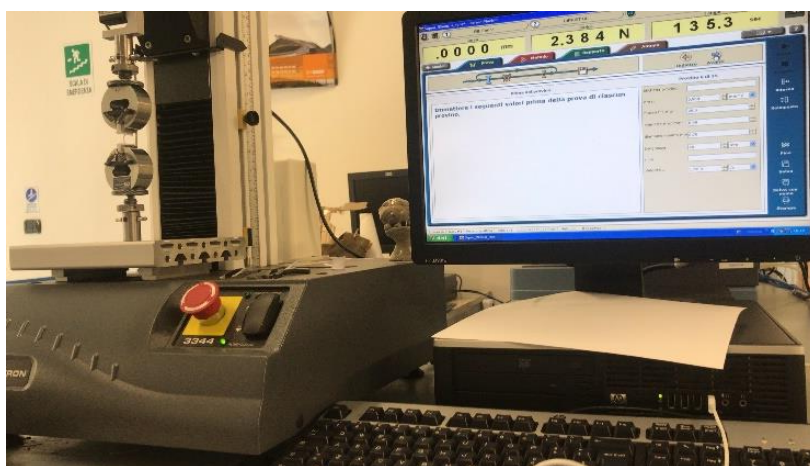
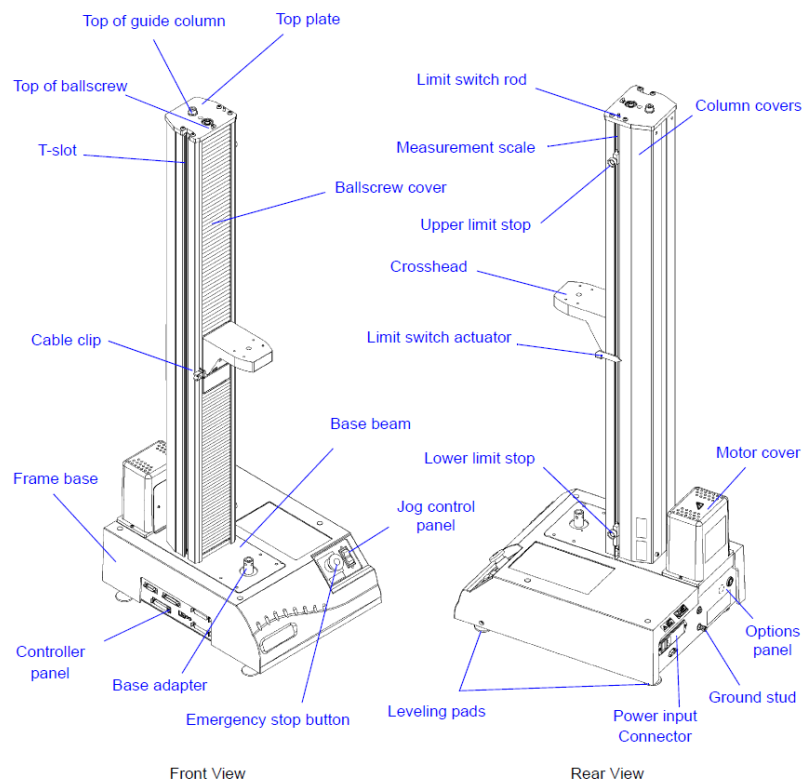

Figure 19 Setting for pullout test

ATOMATIC MORTAR MIXER

The automatic mortar mixer used for preparing the pull-out matrix is very robust and expressly designed for the efficient mixing of cement pastes and mortar, with four automatic sequences of mixing cycle, in compliance with: EN 196-1, EN 196-3:2005, EN 480-1. It has a maximum capacity of 4.7 litres and two speeds can be selected:

- 140 or 285 rpm for the revolving action
- 62 or 125 rpm for the planetary action



Figure 20 Automatic mortar mixer

2 PRIORITY n.1

The major purpose of this work was to measure how temperature influences mechanical properties of samples made of concrete with addition of polypropylene fibers. These polymer fibers were chosen for their low cost and high strength gain over a simple concrete matrix without reinforcement.

The parameters of the fibers were the following:

Diameter: it refers to the nominal diameter that characterizes the fiber which is constant with 0.2/0.3 mm of variance in the total length. Two diameters of 0.75mm and 0.85mm were used to ensure the best performance (usually bigger is the diameter better are the performance). If this parameter is not correct the fiber's adhesion to the cement matrix is not ideal so the reinforcement becomes useless.

Length: as the fibers come from a unique long filament of polypropylene the error in the cutting operation is negligible so fibers of 30mm and 50mm were used. This parameter is the most important for the workability of the concrete because pouring the mix into molds with sharp edges is always very difficult.

Geometry: after the extrusion and cutting process of polypropylene the fibers are superficially deformed to ensure a better adhesion to the concrete matrix; two most used geometries are commonly called crimping and embossing.

Dosage: the fibers added to a concrete mix always improve the flexural strength so two different dosage of 4.5 Kg/m³ and 9 Kg/m³ were tested. Like the length parameter the dosage influences negatively the workability of the concrete mix so is kept low into a maximum limit.

2.1 SAMPLE MAKING

To study the effect of temperature on FRC concrete flexural strength we decided to create different samples with the same mix design and differentiate them by using different type of fibers. Combining the mix with all the fiber parameters would have led to hundreds of different mixes involving excessive effort. So we decided to use a software called MINITAB witch is a statistics package developed at the Pennsylvania State University that automates calculations and the creation of graphs, allowing the user to focus more on the analysis of data and the interpretation of results. In particular MINITAB includes a tool called DOE (design of experiments) which helps the operator investigating the effects of input variables (fibres variables) on an output variable (flexural strength) at the same time. Minitab DOE commands include the following features:

- Catalogs of designed experiments to help you create a design
- Automatic creation and storage of your design after you specify its properties
- Display and storage of diagnostic statistics to help you interpret the results
- Graphs to help you interpret and present the results

The succeeding are all the commands inserted in MINITAB to create the DOE outputs:

1. Choose **File > New > Project**.
2. Choose **Stat > DOE > Factorial > Create Factorial Design**.

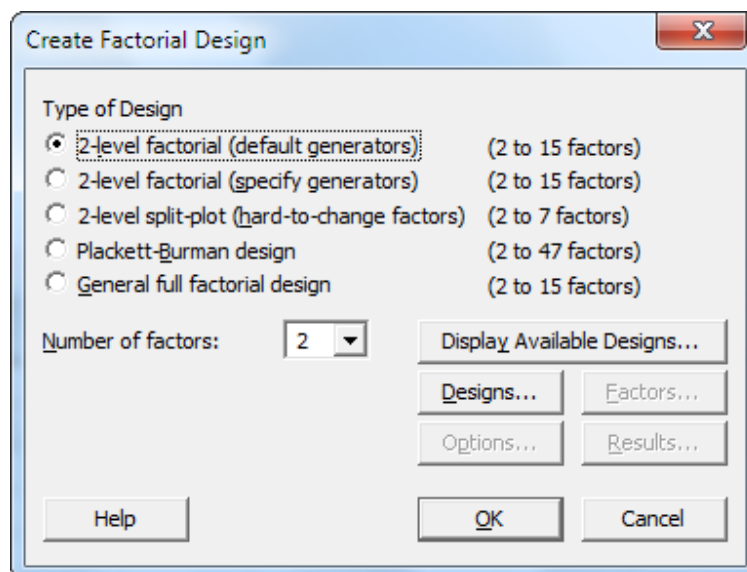

When you create a design in Minitab, only two buttons are enabled, **Display Available Designs** and **Designs**. The other buttons are enabled after you complete the **Designs** sub-dialog box.

3. Click **Display Available Designs**.

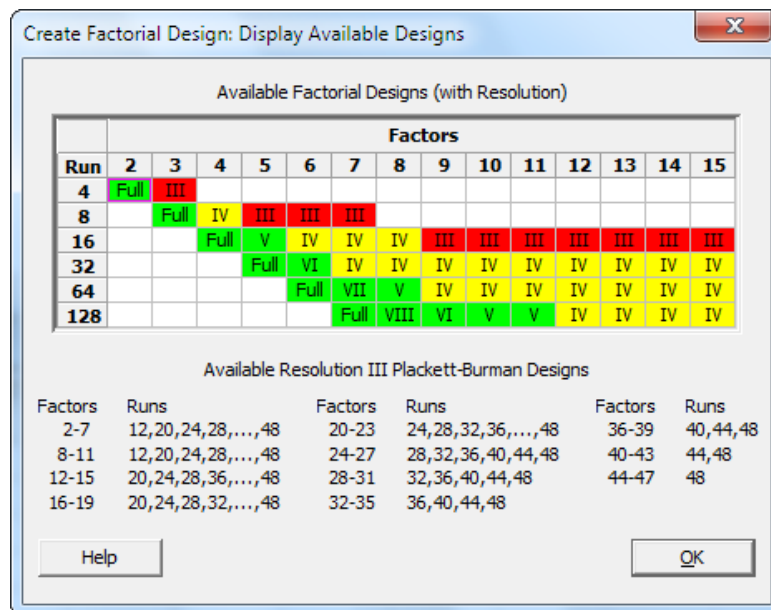

For most design types, Minitab displays all the possible designs and the number of required experimental runs in the **Display Available Designs** dialog box.

4. Click **OK** to return to the main dialog box.
5. Under **Type of Design**, select **2-level factorial (default generators)**.
6. From **Number of factors**, select **2**.
7. Click **Designs**.

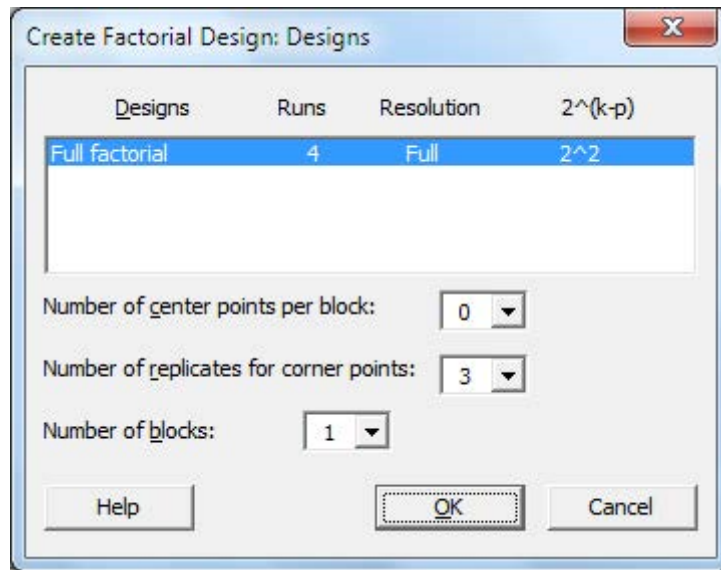

The area at the top of the sub-dialog box shows available designs for the design type and the number of factors that you chose. In this example, because you are performing a factorial design with two factors, you have only one option, a full factorial design with four experimental runs. A 2-level design with two factors has 2^2 (four) possible factor combinations.

8. From **Number of replicates for corner points**, select **3**.
9. Click **OK** to return to the main dialog box. All the buttons are now enabled. Enter the factor names and set the factor levels

Minitab uses the factor names as the labels for the factors on the analysis output and graphs. If you do not enter factor levels, Minitab sets the low level at -1 and the high level at 1 .

1. Click **Factors**.
2. In the row for **Factor A**, under **Name**, enter *Order System*. Under **Type**, select **Text**. Under **Low**, enter *New*. Under **High**, enter *Current*.
3. In the row for **Factor B**, under **Name**, enter *Pack*. Under **Type**, select **Text**. Under **Low**, enter *A*. Under **High**, enter *B*.

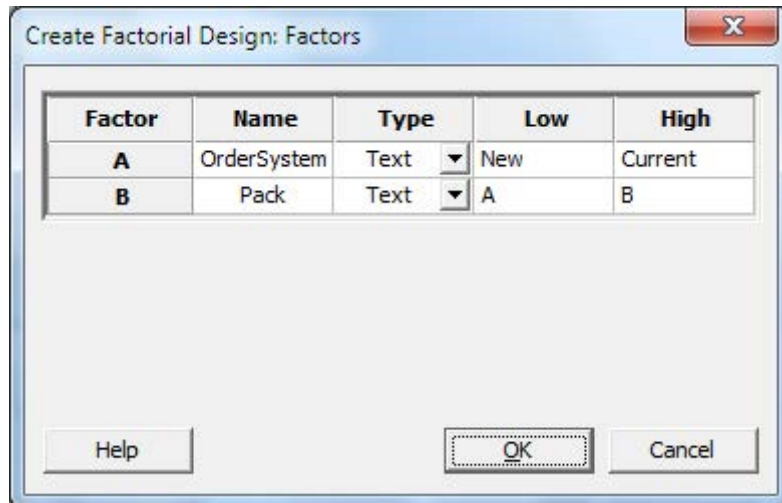

4. Click **OK** to return to the main dialog box.

This is the final table showing the parameters of the fibers to be used in the sixteen different sample group (as ASTM the minimum number of samples for each test is of six):

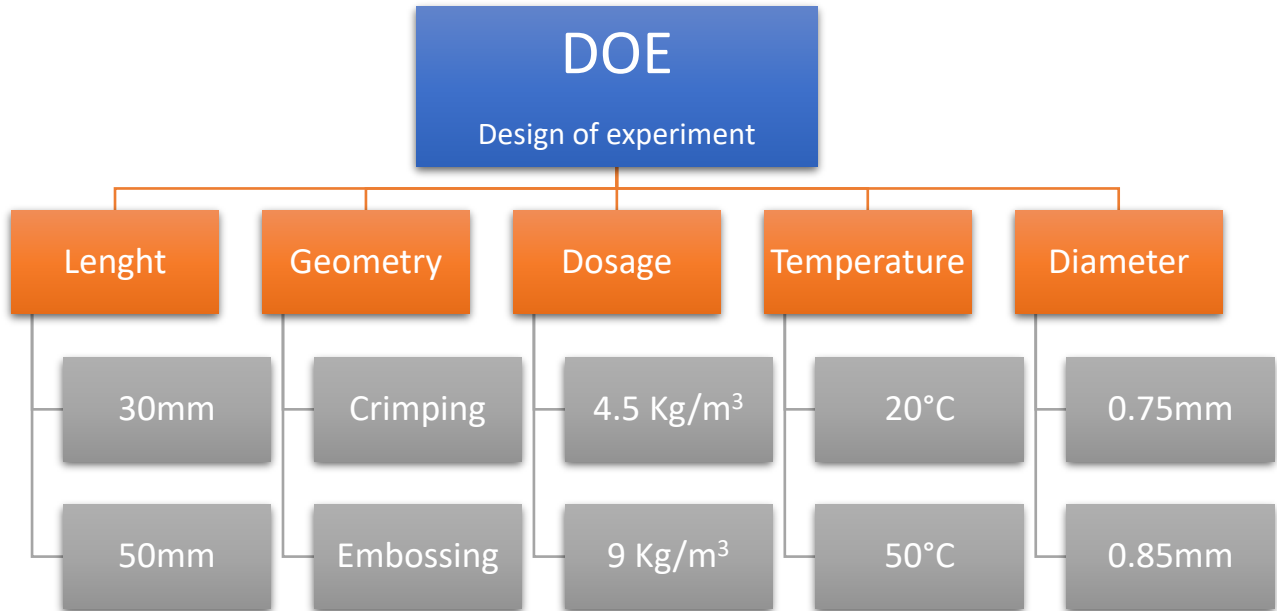

MIX DESIGN Dmax 20 mm

Fractional Factorial DOE

RunOrder	Blocks	Diametro, mm	Aggrappo	Lunghezza, mm	Dosaggio, kg/m3	Temperatura, °C
1	4	0.75	Crimping	30	9	20
2	4	0.85	Embossing	50	9	50
3	4	0.85	Embossing	50	4.5	20
4	4	0.75	Crimping	30	4.5	50
5	1	0.75	Embossing	50	9	20
6	1	0.75	Embossing	50	4.5	50
7	1	0.85	Crimping	30	9	50
8	1	0.85	Crimping	30	4.5	20
9	2	0.85	Embossing	30	4.5	50
10	2	0.75	Crimping	50	9	50
11	2	0.85	Embossing	30	9	20
12	2	0.75	Crimping	50	4.5	20
13	3	0.75	Embossing	30	4.5	20
14	3	0.85	Crimping	50	4.5	50
15	3	0.85	Crimping	50	9	20
16	3	0.75	Embossing	30	9	50

The concrete mix components were the following:

- Aggregate P1 (size of 8-12mm);
- Aggregate P2 (size of 12-19mm);
- Mosole (similar to fine beach sand);
- Cement;
- Additive MasterGlenium 623;
- MasterFiber 246;
- Water;

The samples were prepared by adding in different steps all the ingredients into the cement mixer of maximum volume capacity of 50 liters. In order to maintain the right proportion of all the ingredients we had to calculate the amount in kilograms for a mix volume as small as the mixer we used. Initially the two aggregates (Mosole and aggregate P2) were versed into the mixer with half water and with all the fibers and simply mixed for one minute to make the whole mixture more homogeneous. Then the cement was added into the mixer and the rest of the water with it. After one other minute of mixing the additive was poured.



Figure 21 First stage of preparation FRC concrete before mixing



Figure 22 First stage of preparation FRC concrete after mixing

Once the mix was ready the concrete was poured into the metal formworks previously wet with disarmingly synthetic oil. The samples were stored for a night time in the laboratory and then placed into maturation room with constant humidity (100%) and constant temperature (20°C). The store took 21 days before testing and in the meanwhile other project where carried on.

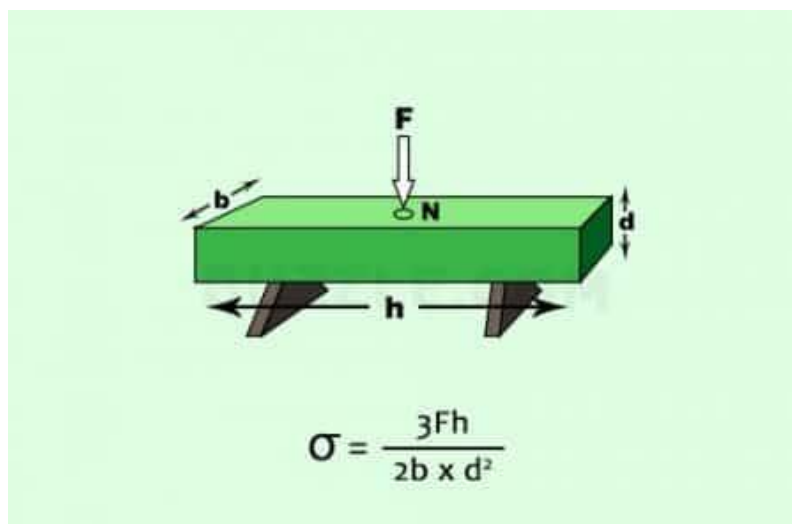

Figure 23 Pouring phase after mixing

2.2 SAMPLE TESTING

All the samples were made of the same dimensions of 15x15x60 cm³ based on the ASTM UNI EN ISO 14651 standard and tested on an Instron machine to measure the flexural strength of the composite by applying at the center of the beam's span length the load until a crack of four mm of aperture is reached.

All the samples had been carved in the center of the major length to make the flexural crack start from that specific point. The engrave was obtained from a cutting machine with 0.5 cm in width and 25 mm in depth. Before putting the samples on the Instron machine the sample and the engrave had been accurately measured with a caliber on the three dimensions and all the data inserted in the Instron software to ensure the machine could better measure the stress during the test. Once taken all the geometrical data the samples were loaded on the Instron by leaning on two fixed supports while the third was moving from the top with a variable load depending on the crack aperture.



For a rectangular sample under a load in a three-point bending setup the equation for calculating the stress is the one shown in figure above where

- F is the load (force) at the fracture point (N)
- L is the length of the support span
- b is width
- d is thickness

The placement of the samples was very precise: after placing it on the two lower brackets the third one was lowered from the top of the machine and slowly approached to the top surface of the sample.

The final step was to level out the third bracket. On the Instron software the maximum stress measured before starting the test must be lower than 3 kN so when the bracket is positioned correctly the pressure on the sample is lowered as much as possible.

After 20 minutes of testing the sample is being removed and crushed completely by lowering the superior bracket: this final operation allows the operator to ensure the PP fibre distribution and to estimate how many of them have been pulled out from the matrix and how many have been stretched until the rupture.



Figure 24 Setting of Instron machinery with three points flexion. Particular of the sensor under the sample

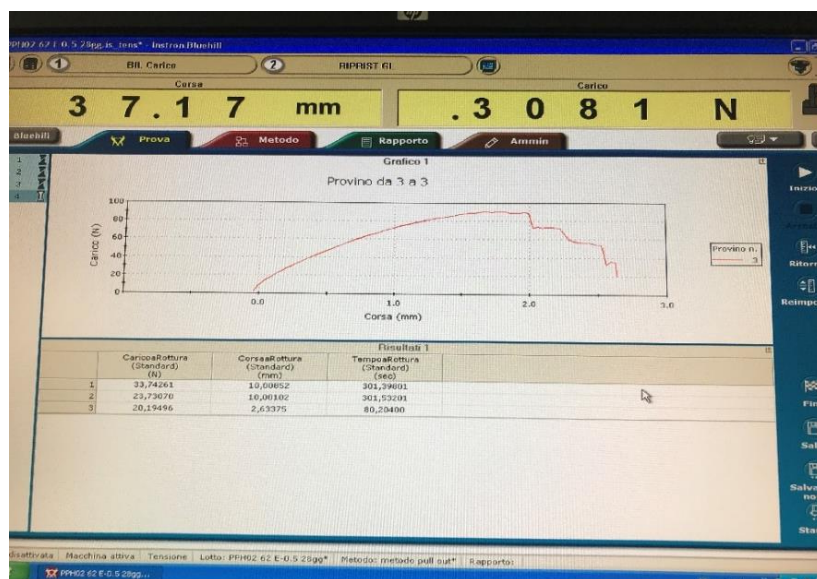

Figure 25 Image of the software of Instron machinery

3 PRIORITY n.2

In this second part of the project the purpose was to study two different mix type of FRC concrete called Ready-mix and Precast made of a specific mix design to better understand the behavior of the composite in different situations like different humidity or variation of the mix design.

The sample making process was the equal for both the concrete mix and it is composed by the same stages as the previous samples of priority n.1.

3.1 READYMIX

ReadyMix guide chart:

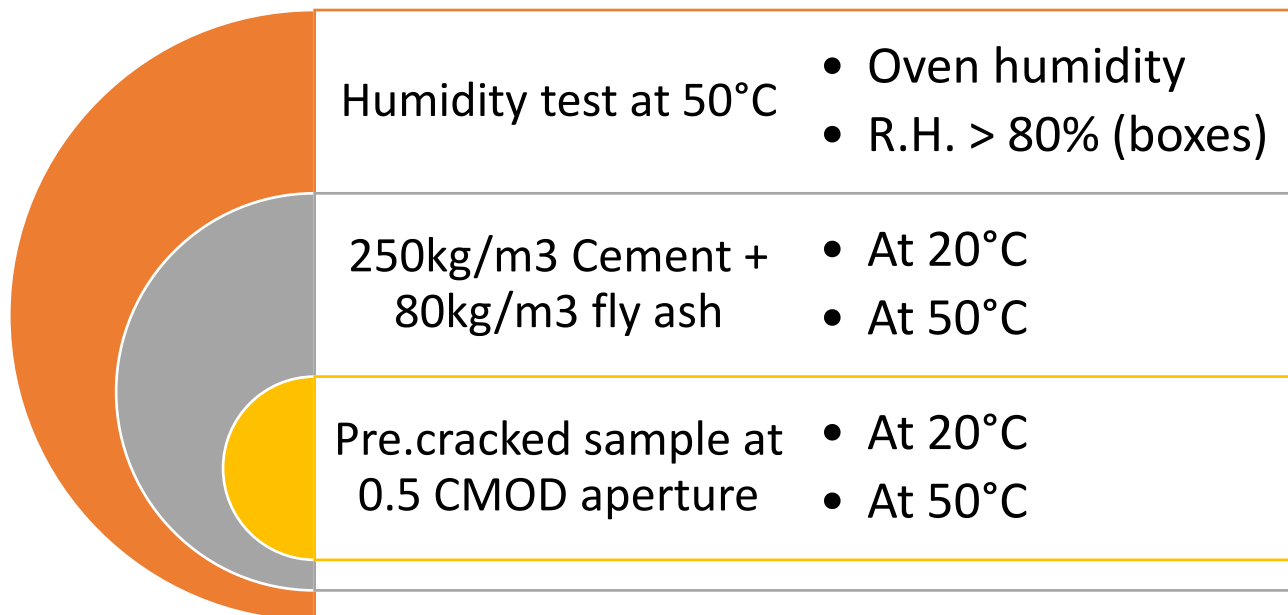

Strength, durability and workability are at the forefront of challenges faced by readymix concrete producers as well as the need for concrete that is aesthetically pleasing, more sustainable and safer to use. Admixtures like this allow to increase the service life of concrete, speed of construction, environmental efficiency and liquid colouring products for aesthetically pleasing architectural concrete.

The readymix concrete mix composition is showed below:

Mix Type	Cement type	Dosage	P1 agg	P2 agg	Mosole	G 5,15	G25	MAC SKY 623	FYBER TYPE	Dosage	Water
ReadyMix	42,5R II/A-LL	330	138	277	1010	138	277	2,2	246	4,5	192

*All units are in kg/m³

- Aggregate P1 is gravel with diameter from 8 to 12 mm;
- Aggregate P2 is gravel with diameter from 12 to 19 mm;
- Mosole is similar to fine beach sand;
- MasterGlenium ACE 623 is the additive used.

- Humidity test

For the humidity test we decided to study the effect of flexural strength on FRC concrete after 24 hours stored into an oven with controlled temperature and water-content of air. The humidity of the oven and the temperature were kept constant as shown in these graphs:

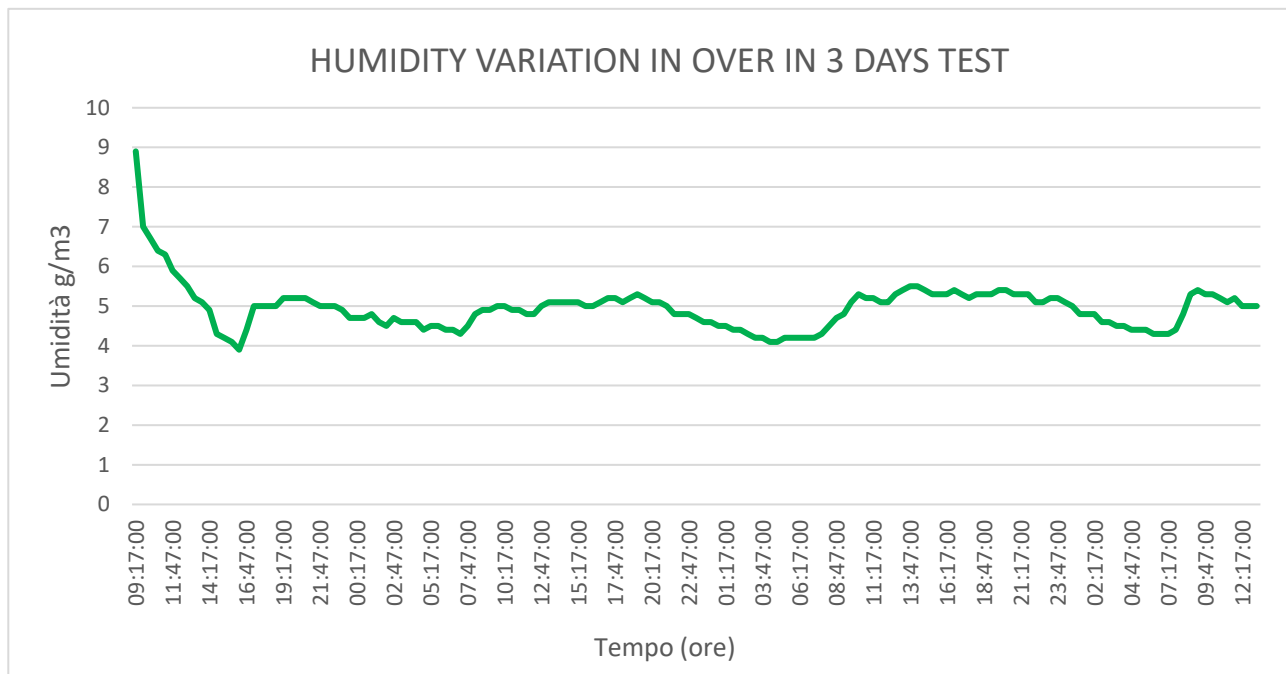

Six samples were stored into the oven for 24 hours at 50°C in ambient humidity ($\approx 5\%$) and other six samples were put into hermetic boxes with wet sand in order to emulate high water concentration atmosphere.

- Fly ash

For this test we decided to modify the mix design of the ReadyMix mixture lowering the amount of the cement from 330 Kg/m^3 to 250 Kg/m^3 with the addition of 80 Kg/m^3 of fly ash.

Fly ash is a fine powder that is a waste product of burning pulverized coal in electric generation power plants. Fly ash is a pozzolan, a substance containing aluminous and siliceous material that forms cement in the presence of water. When mixed with lime and water, fly ash forms a compound similar to Portland cement. This makes fly ash suitable as a prime material in blended cement, mosaic tiles, and hollow blocks, among other building materials. When used in concrete mixes, fly ash improves the strength and segregation of the concrete and makes it easier to pump. Fly ash can be a cost-

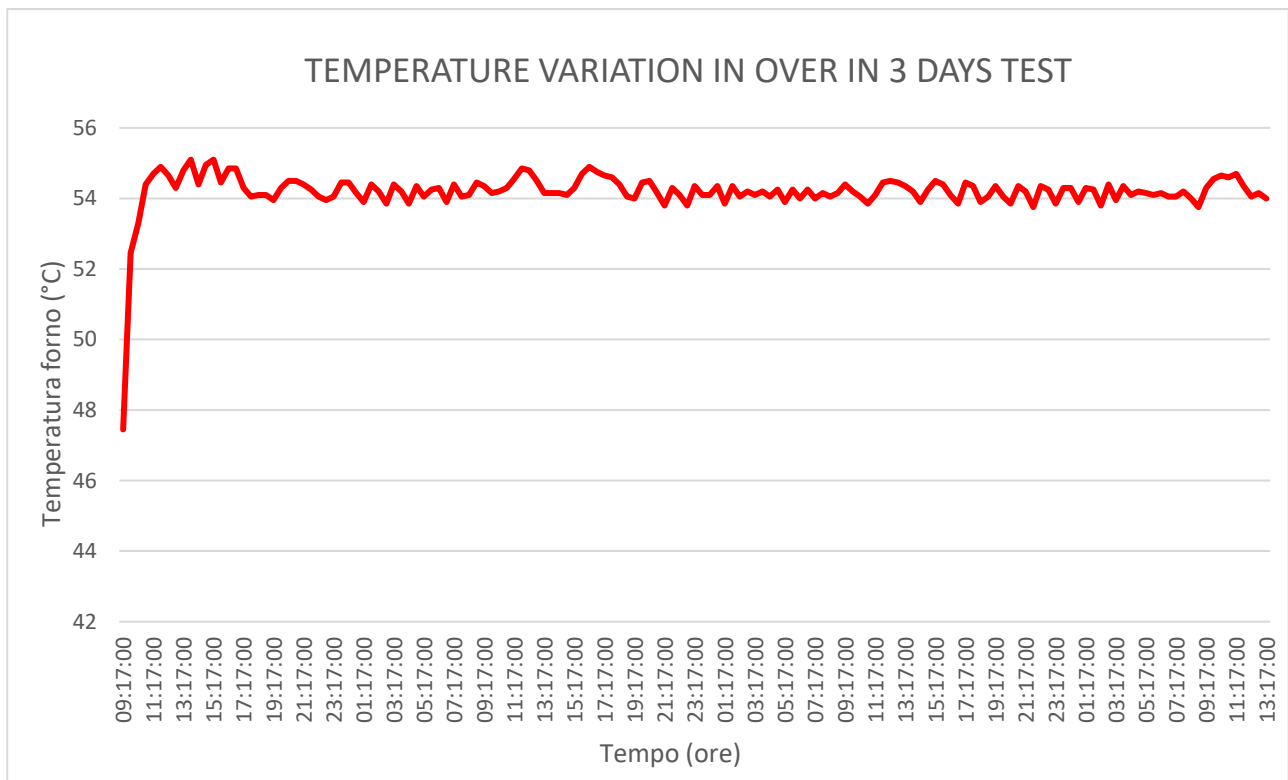

effective substitute for Portland cement in many markets and is also recognized as an environmentally friendly material because it is a waste product and has low *embodied energy*, the measure of how much energy is consumed in producing and shipping a building material.

Two different tests were performed at ambient temperature of 20°C and at 50°C.

- Pre-Crack flexural test

This ultimate test was provided to measure the flexural strength depending on the CMOD value of samples without any modification on the mix design. The modus operandi was to test the sample and to stop the bending after reaching COMD equal to 0.5mm (FR1 strength value). After that the sample is unloaded and removed temporarily from the Instron machine and then repositioned. Now the test is executed as normal until the COMD aperture reaches 4 mm opening.

3.2 PRECAST

Precast guide chart:

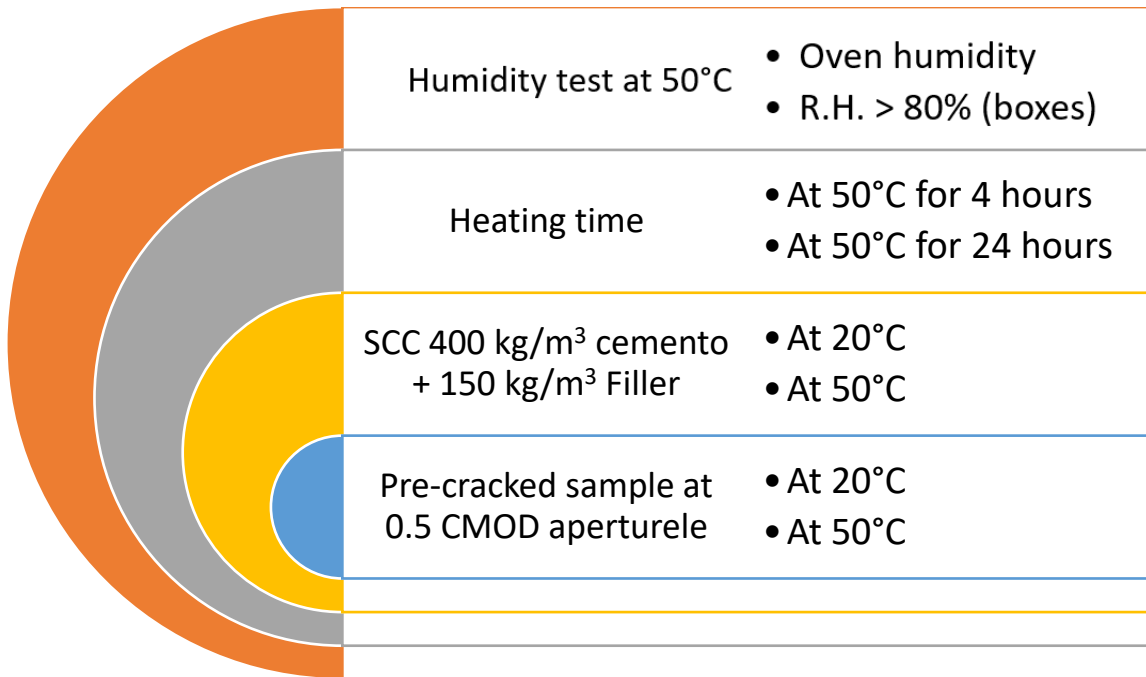

This type of concrete mix is developed by BASF for the Master Builder Solutions brand to increase quality, productivity and to reduce the costs in tight production schedules. This innovative admixture technology improves strength, aesthetics and durability of concrete elements, with additives addition it ensures the desired slump retention performance and surface finish.

The ready-mix concrete mix composition is showed below:

Mix Type	Cement type	Dosage	P2 agg	Mosole	MAC SKY 623	FYBER TYPE	Dosage	Water
Precast	52,5l Mons.	380	845	1035	2,9	246	9	190

*All units are in kg/m³

- Humidity test

as for ReadyMix we studied the effects of storing for 24 hours the samples into an oven with controlled temperature and relative humidity index. Six samples were put in ambient humidity and other six at $RH > 80\%$;

- Heating test

concrete samples were tested with two different storing times at the same temperature of 50°C to study the influence of high temperature on flexural strength;

- SCC + filler

Self-consolidating concrete or self-compacting concrete (SCC) is a concrete mix with low yield stress, high deformability, good segregation and moderate viscosity. After the mixing stage, when the concrete mix is poured into molds, SCC results an extreme fluid mix with the following distinctive practical features

1. it flows very easily within and around the formwork;
2. can flow through obstructions and around corners ("passing ability");
3. is close to self-leveling (although not actually self-levelling);
4. does not require vibration or tamping after pouring;
5. follows the shape and surface texture of a mold (or form) very closely once set

- Pre-Crack flexural test

this ultimate test was provided to measure the flexural strength depending on the CMOD value of samples without any modification on the mix design. The modus operandi was to test the sample and to stop the bending after reaching COMD equal to 0.5mm (FR1 strenght value). After that the sample is unloaded and removed temporarily from the Instron machine and then repositioned. Now the test is executed as normal until the COMD aperture reaches 4 mm opening.

4 Pullout Test

This test is made to measure the maximum strength needed to pull a single fiber out from a mortar weathered at least one week. During the operation the fiber is not supposed to break and the graph plotting the relation between the movement and the force presents different peaks. These are some figures to show the setting:

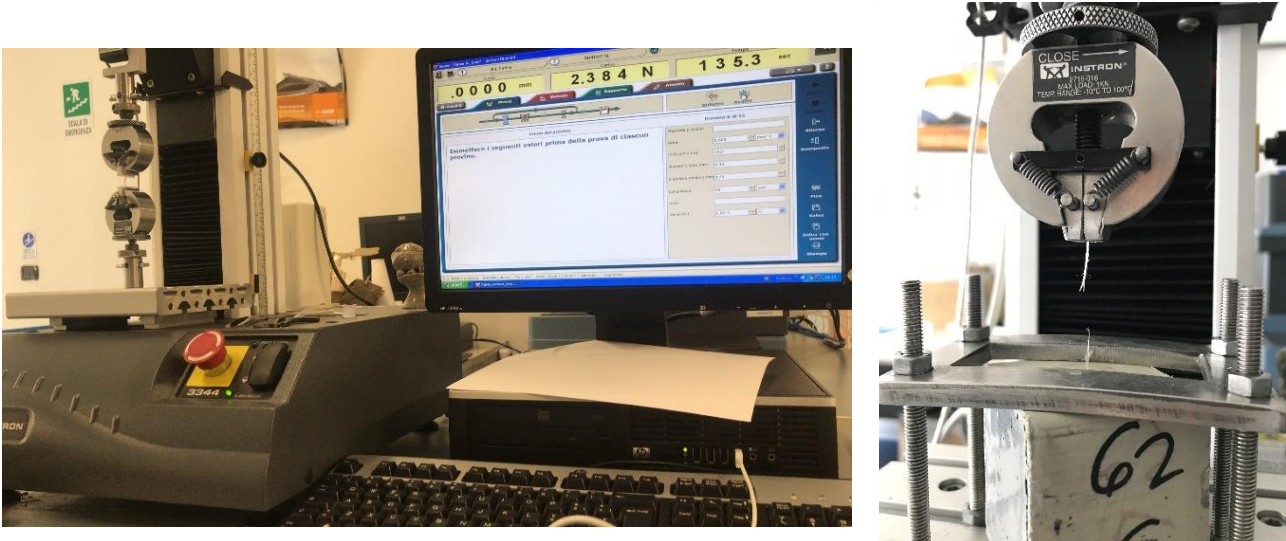

Figure 26 Setting of pullout test with the software used and the clamp system for samples

As in fig. the sample is positioned vertically with the fiber coming out from the top hole and strongly fixed on the Instron[®] machine secured with 4 screws. The clamp coming from the top is positioned very close (about 1 or 2 millimeters) from the sample surface and the fiber is tightened manually. The resulting graph shows different peaks relative to the maximum force at current excursion of the clamp caused by the mechanical interaction between the fiber and the mortar matrix. The combination of fiber geometry and mortar aggregates determines the resistance of pullout.

4.1 SAMPLE MAKING

The making of the samples required the preparation of the mortar and a delicate operation of positioning the fiber into a rigid support. The first step was to mix all the following components into a mortar mixer:

1. Normalized sand (2700g);
2. Cement (I - 42.5) (900g);
3. Fly ash (150g);
4. Water (450g);
5. Additive 1: MasterGlenium Ace 440 (6g);
6. Additive 2: Rheomatrix 150 (6g);

The procedure starts with combining water, normalized sand, cement and fly ash into a metal pot adding the first additive MasterGlenium Ace; this type of additive allows to obtain an advanced development of the heat of hydration and to improve the mechanical resistance to the short curing periods.

After 30 seconds at minimum speed of the mixer the compound is left to rest for another 30 seconds meanwhile the second type of additive (Rheomatrix 150) is added to increase the viscosity of the mortar matrix and in particular for self-compacting mixtures with low content in fine materials.

The final stage is to speed up the mixer to its maximum speed for 210 seconds to obtain a homogeneous mixture.

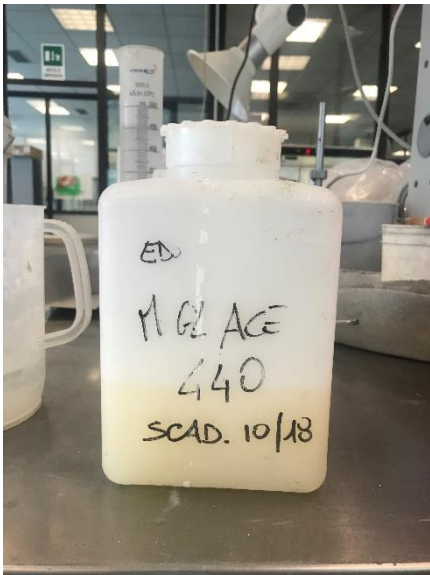

Figure 27 Image of the additive MasterGlenium ACE 440 used for mortar and the cement sample



Figure 28 Mortar mix before mixing



Figure 29 Mortar mix after mixing

All the samples have been prepared by positioning into a holed PVC cage one single fiber of PP (Masterfiber 246) hanged with a small piece of modeling clay and then pouring the mortar inside the cage itself. Before mixing the components of the mortar all the PVC cages are prepared with the fibers inserted for 10 mm and positioned vertically inside the cage. In the filling operation of the cases particular attention is given in order not to move or shift the fiber so during the extraction test (pullout) it is minimum the error of the measurement.



Figure 30 Exemple of a sample with the fiber attached on the top ready to be filled with mortar



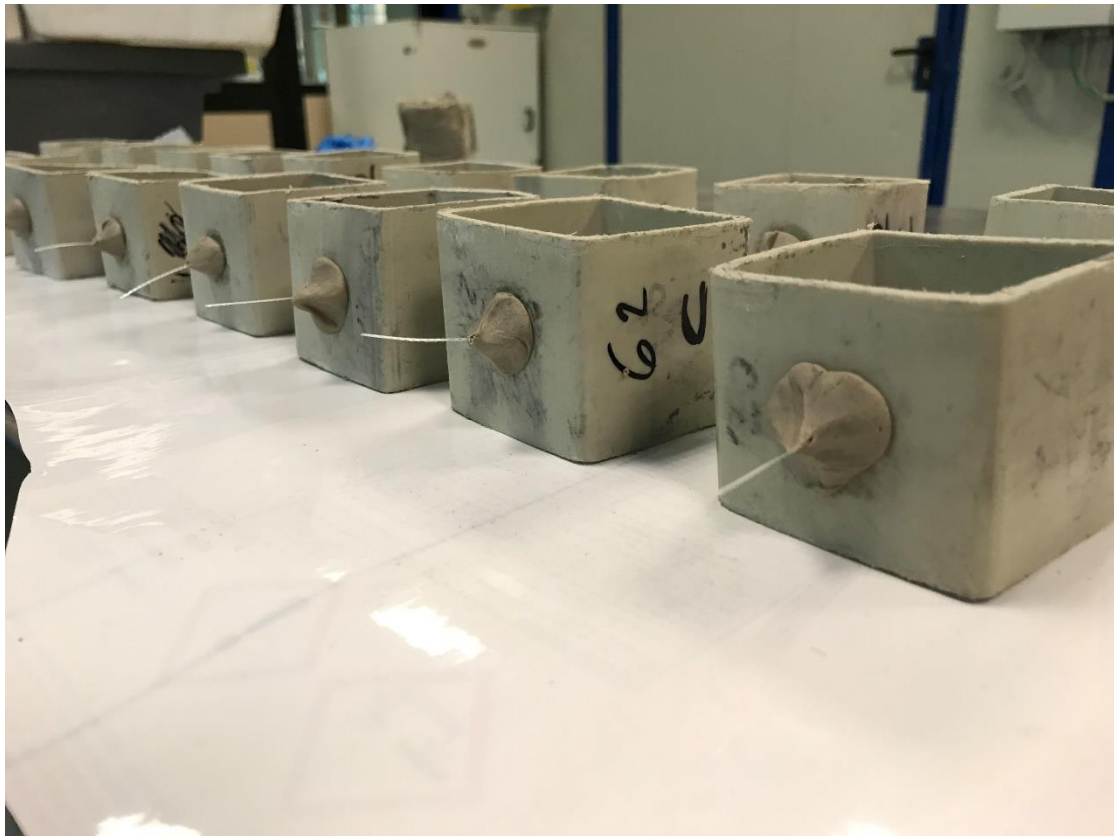

Figure 31 Steps of preparation for pullout test samples

For the pullout test were prepared in total 120 samples with mortar maturation of seven days (one week at room temperature):

GEOMETRY	DIAMETER (mm)	TEMPERATURE	NUMBER OF SAMPLES
CRIMPING	0,85	20°C	10
		50°C	10
	0,75	20°C	10
		50°C	10
	0,5	20°C	10
		50°C	10
EMBOSSING	0,85	20°C	10
		50°C	10
	0,75	20°C	10
		50°C	10
	0,5	20°C	10
		50°C	10

For the pullout test were prepared in total 80 samples with mortar maturation of twenty-eight days (four weeks at room temperature):

GEOMETRY	DIAMETER	TEMPERATURE	NUMBER OF SAMPLES
CRIMPING	0,85	20°C	10
		50°C	10
	0,5	20°C	10
		50°C	10
EMBOSSING	0,85	20°C	10
		50°C	10
	0,5	20°C	10
		50°C	10

4.2 SAMPLE TESTING

First step is to calibrate the Instron machine to ensure the load is zero at the beginning of the test. After mounting the clamp on the top (in this case the model with 1KN of maximum pull-force) the sample is fixed on the bottom base and secured with four screws. The clamp is then lowered and positioned ca. 1-2 mm from the sample centering the fiber on the two grips. Once the set is complete, via software the sensor is reset in order to zero the load and the shift.



Figure 32 Setting of pullout test on Instron machine



Figure 33 Closer look to setting of the clamp in pullout test

5 RESULTS

5.1 PRIORITY n.1

Mix No.	Diameter (mm)	Type	Length (mm)	Dosage (Kg/m3)	Temperature	FR1	FR3	FR3/FR1
1	0,75	Crimping	30	9	20	2,29	2,25	0,98
2	0,85	Embossing	50	9	50	2,13	2,42	1,14
3	0,85	Embossing	50	4,5	20	1,65	1,52	0,92
4	0,75	Crimping	30	4,5	50	1,58	1,11	0,70
5	0,75	Embossing	50	9	20	2,6	3,63	1,40
6	0,75	Embossing	50	4,5	50	1,26	1,12	0,89
7	0,85	Crimping	30	9	50	2,31	3,28	1,42
8	0,85	Crimping	30	4,5	20	1,24	1,4	1,13
9	0,85	Embossing	30	4,5	50	1,34	0,72	0,54
10	0,75	Crimping	50	9	50	2,09	2,67	1,28
11	0,85	Embossing	30	9	20	2,15	2,15	1,00
12	0,75	Crimping	50	4,5	20	1,35	1,6	1,19
13	0,75	Embossing	30	4,5	20	1,43	1,27	0,89
14	0,85	Crimping	50	4,5	50	1,58	1,38	0,87
15	0,85	Crimping	50	9	20	2,37	3,24	1,37
16	0,75	Embossing	30	9	50	1,72	1,49	0,87



Concrete Fiber-reinforced
Average Specimen 150x150x600mm
Maturation 21 dd - bending test

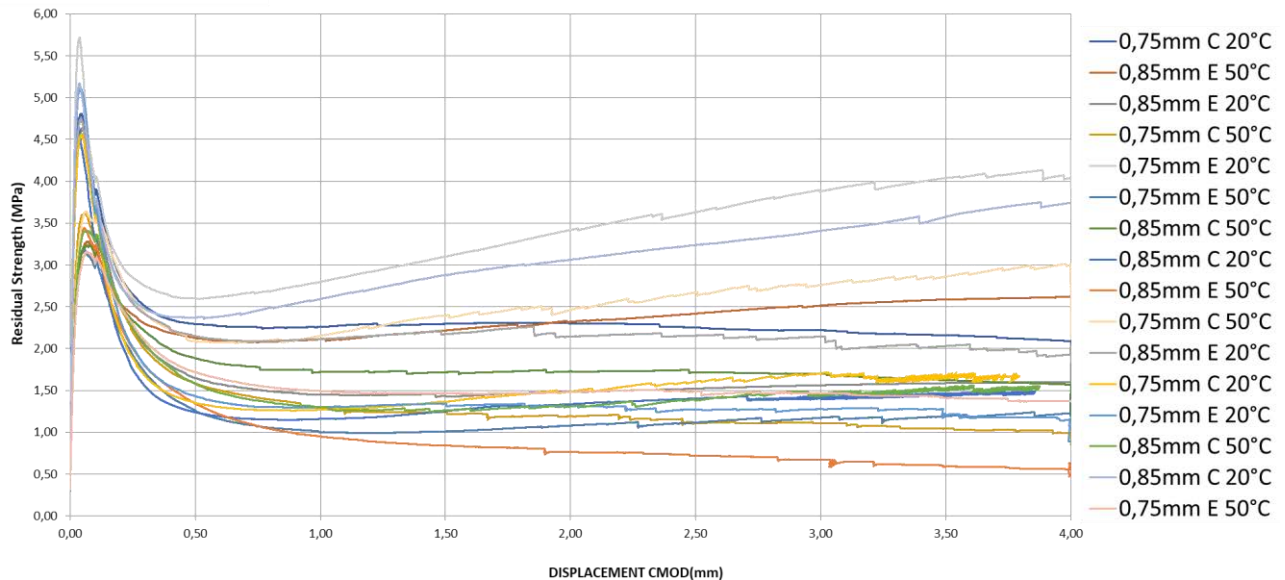

The analysis for flexural strength was made considering the data obtained from the tenacity graphs where is possible to estimate two important values known as FR1 and FR3 which represent the strength response of the FRC under a certain load at a given CMOD aperture (0.5mm for FR1 and 3.5mm for FR3). To analyze these values, we used MINITAB that is capable of estimating the correlation between different types of mix with the flexural strength.

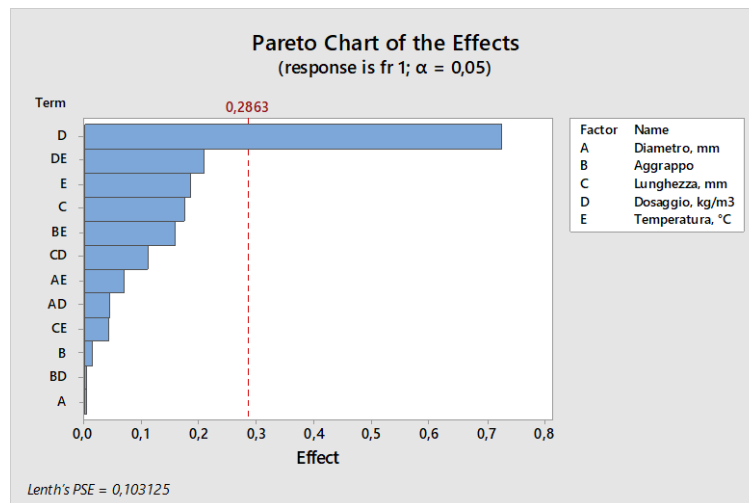

Minitab offers a so called 'Pareto chart' to identify which of all the parameters (or combination of them) has given a major effect on flexural strength during the test. In this particular chart the most effective parameter was the fiber dosage which influenced most the value of FR1 at 0.5mm of CMOD aperture.

All the other parameters of the mix resulted as 'not relevant' from this analysis concerning FR1 performance.

Interaction Plot for fr 1 Means

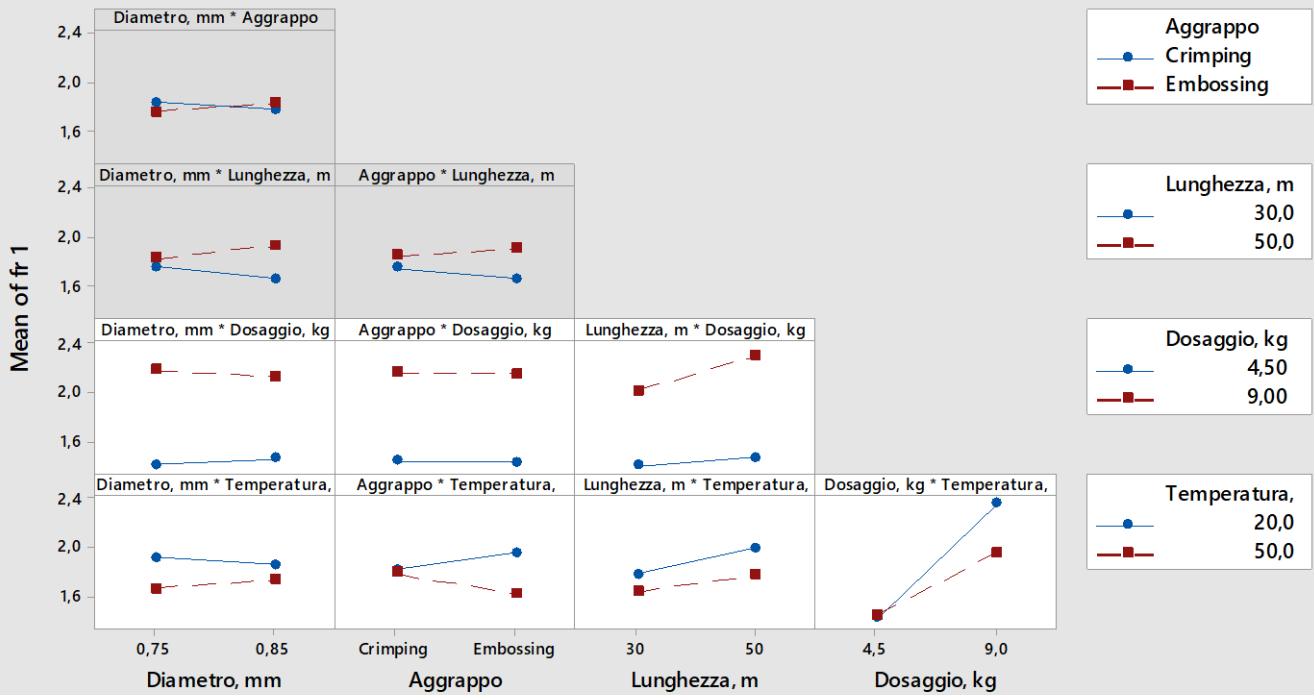

A gray background represents a term not in the model.

These are the interpretation of the graphs above for FR1 performance with all possible correlation between variables of the fibers:

- At 20°C a fiber diameter of 0.75mm gives higher performance instead of at 50°C; at that higher temperature increasing the diameter leads to higher performance but always lower than the 20°C performance;
- Crimping geometry does not show better performance with temperature variation; Embossing geometry gives higher FR1 values at 20°C;
- The length variation of the fibers does not modify the mechanical response of the material;
- With minimum dosage of fibers, the performance is always worst, in particular at 20°C a dosage of 9 Kg/m³ ensure the best performance;
- In the correlation between diameter and dosage the difference in FR1 performance is highly noticeable: 4.5 Kg/m³.

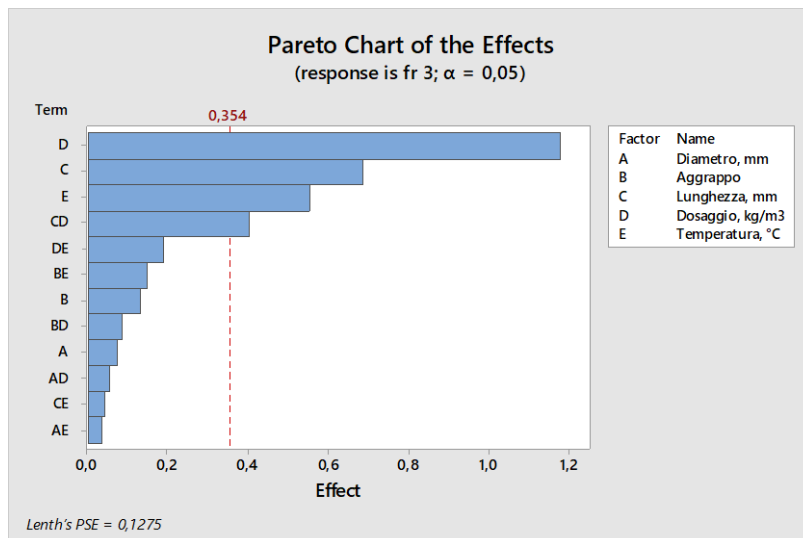

In this 'Pareto chart' used to identify which of all the parameters (or combination of them) has given a major effect on FR3 flexural strength value (3.5mm of CMOD aperture). In particular the dosage represents the most influent variable, as for FR1, then with minor impact on performance length and temperature variables result as most statically significant.

All the other parameters of the mix resulted as 'not relevant' from this analysis concerning FR3 performance.

Interaction Plot for fr 3 Means

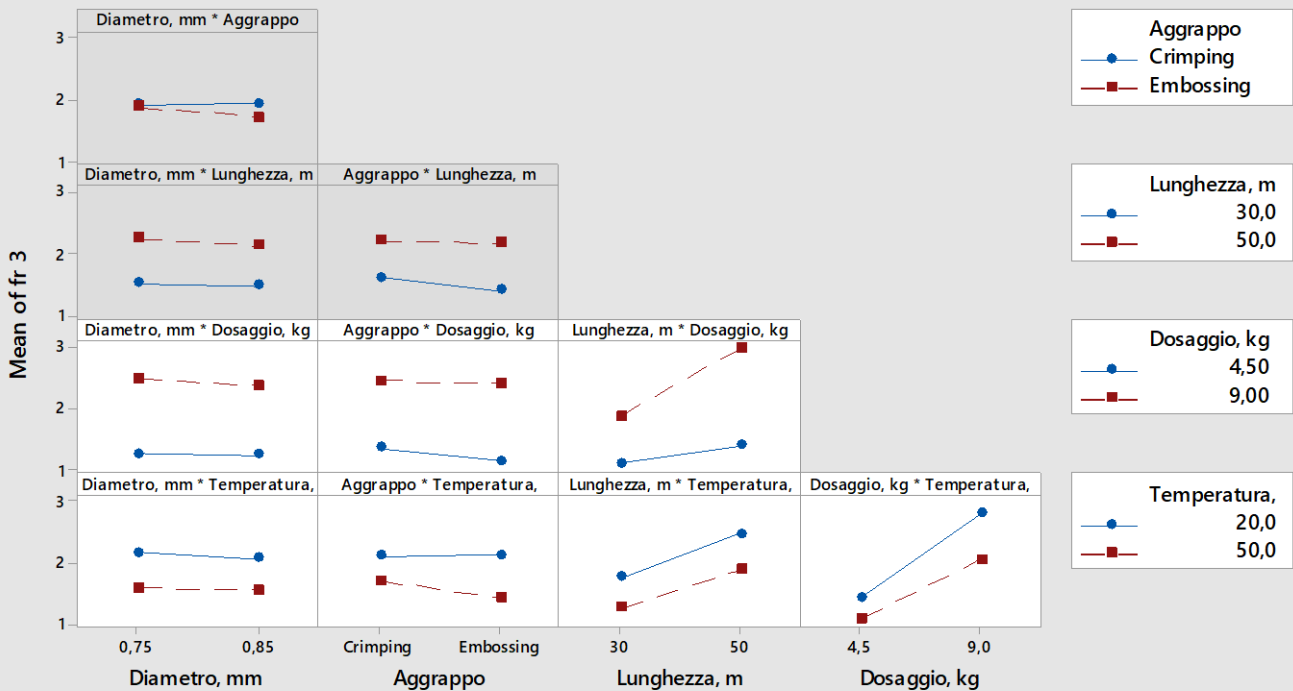

A gray background represents a term not in the model.

These are the interpretation of the graphs above for FR3 performance with all possible correlation between variables of the fibers:

- Both diameters of 0.85 and 0.75 mm present better performance at lower temperature;
- At 20°C the difference in performance between the two fiber geometries is negligible: at 50°C it is noticeable a better performance with crimping geometry which decreases FR3 values at 20°C;
- For both lengths of 30 and 50 mm the highest performance is obtained at lower temperature of 20°C, in particular the combination 30 mm at 20°C – 50 mm at 50°C is comparable;
- The higher is the dosage the better are the performance of FR3 value both at 20°C and 50°C.

These are the final conclusions of the tenacity test analysis from FR1 and FR3 values:

- In all the comparatives the minor temperature ensures better performance;
- The correlation between temperature and diameter of the fibers shows that the difference in performance between the two diameters is negligible;
- The correlation between temperature and geometry of the fiber shows that *crimping* has minor performance variability than *embossing*.
- The correlation between temperature and dosage shows that higher is the fibers quantity higher is the performance overall;
- The correlation between temperature and length shows that at a given length the temperature variation does not lead to better performance.

These are the mix condition to ensure the best performance in flexural strength:

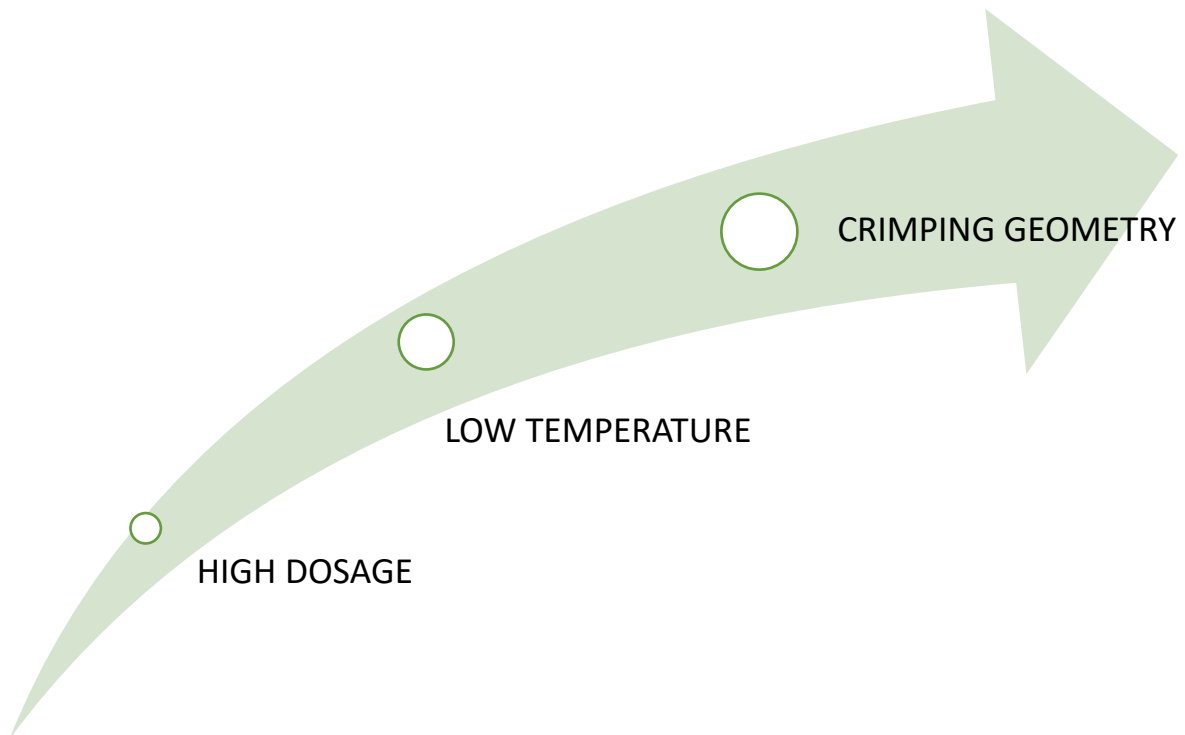



Figure 35 Set of tested samples after final cracking



Figure 34 View of fibers on surface of cracked samples

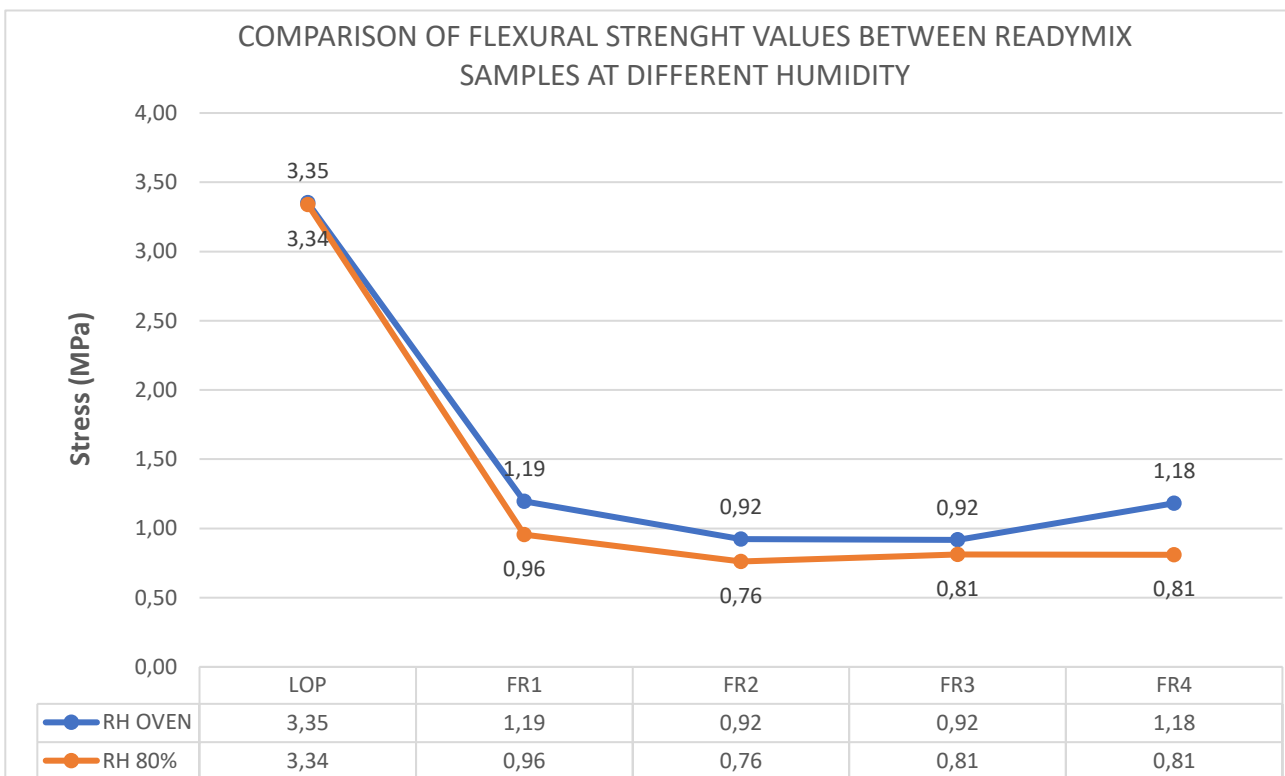
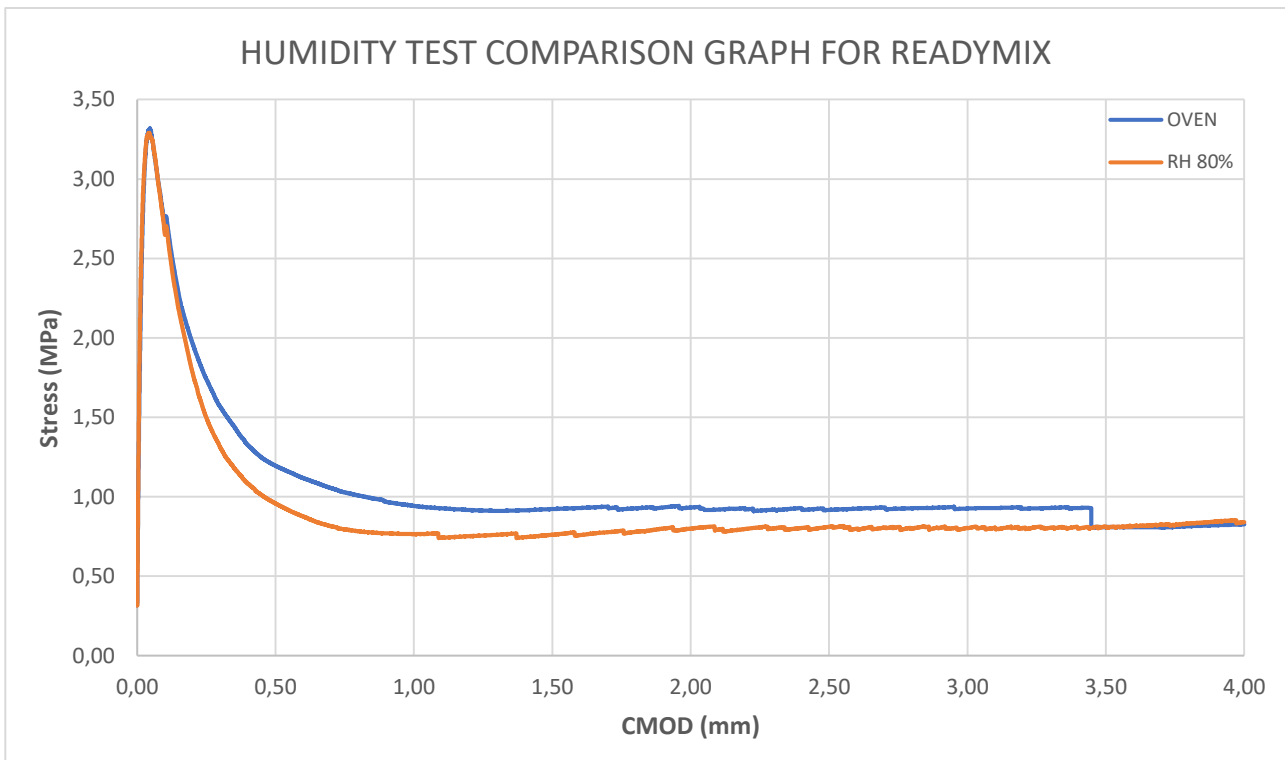

Figure 36 particular of fibers: some are completely frayed/ exhausted, others are still intact due to different behaviour during flexural test



5.2 PRIORITY n.2

5.2.1 READYMIX



FLY ASH ADDITION COMPARISON GRAPH FOR READYMIX

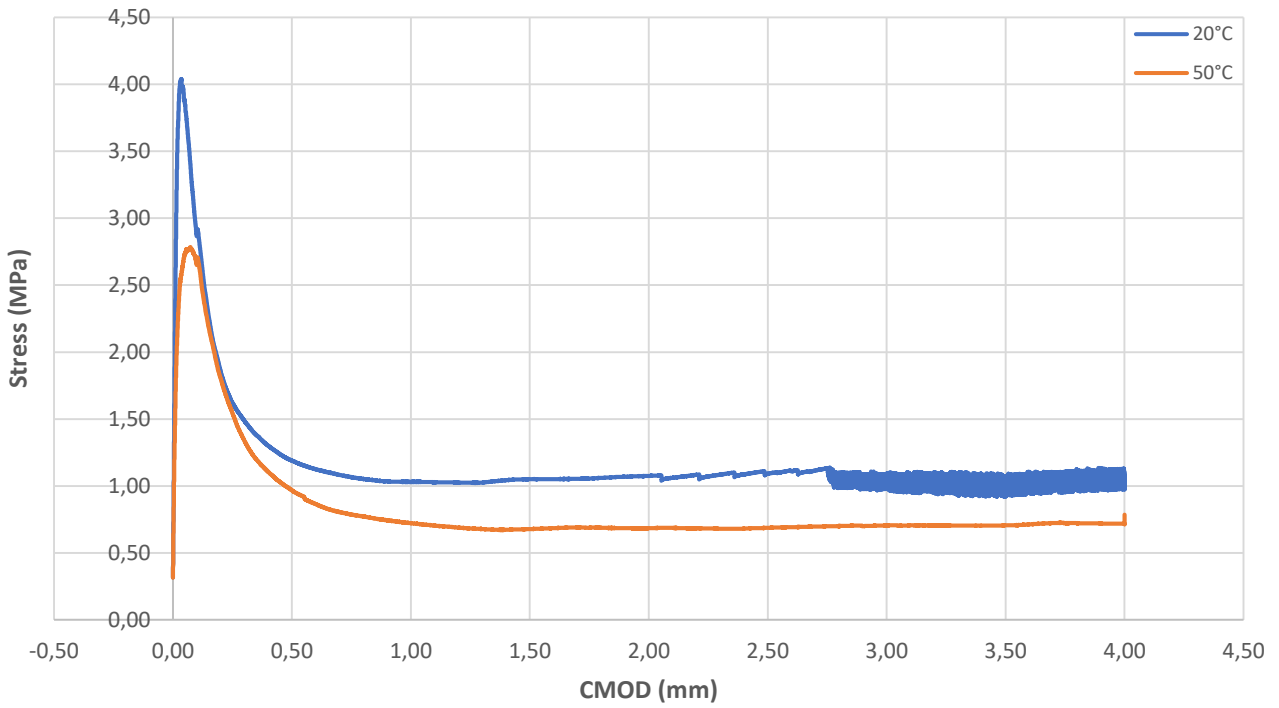

COMPARISON OF FLEXURAL STRENGTH VALUES BETWEEN READYMIX SAMPLES WITH FLY ASH ADDITION

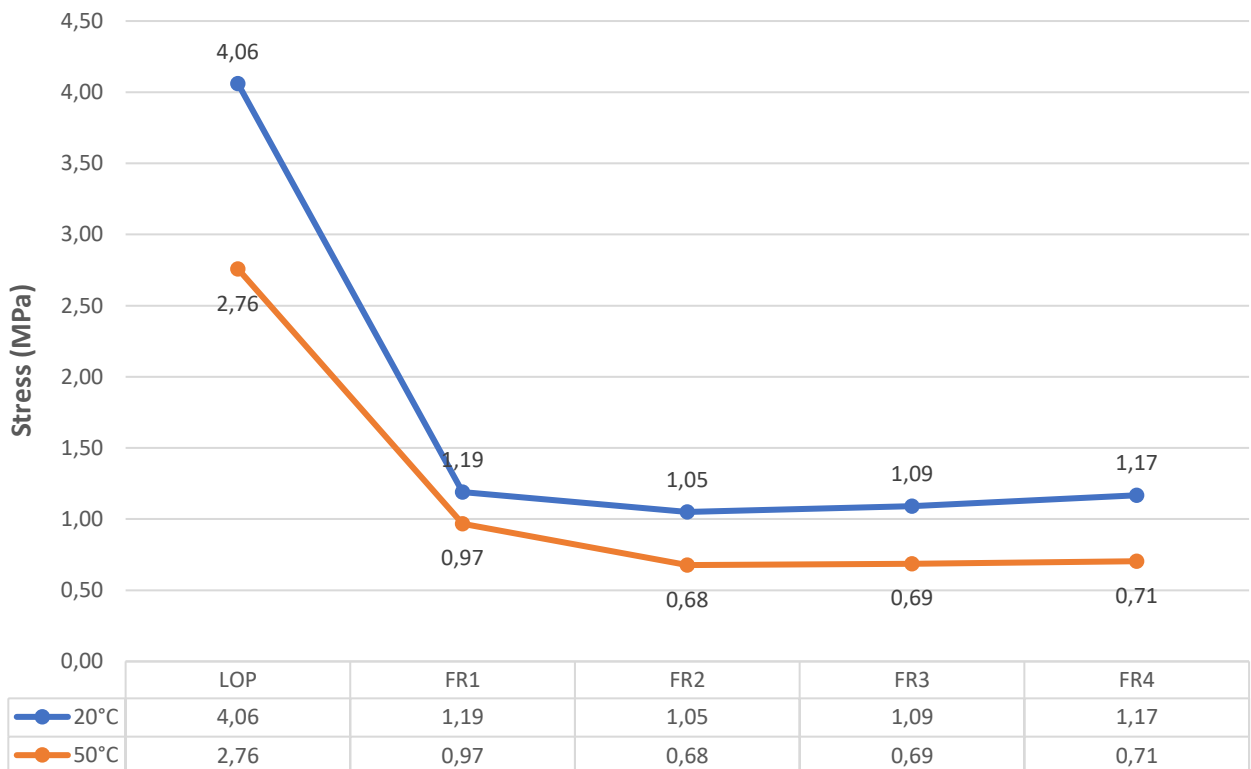

PRE-CRACK COMPARISON GRAPH FOR READYMIX - FIRST STAGE

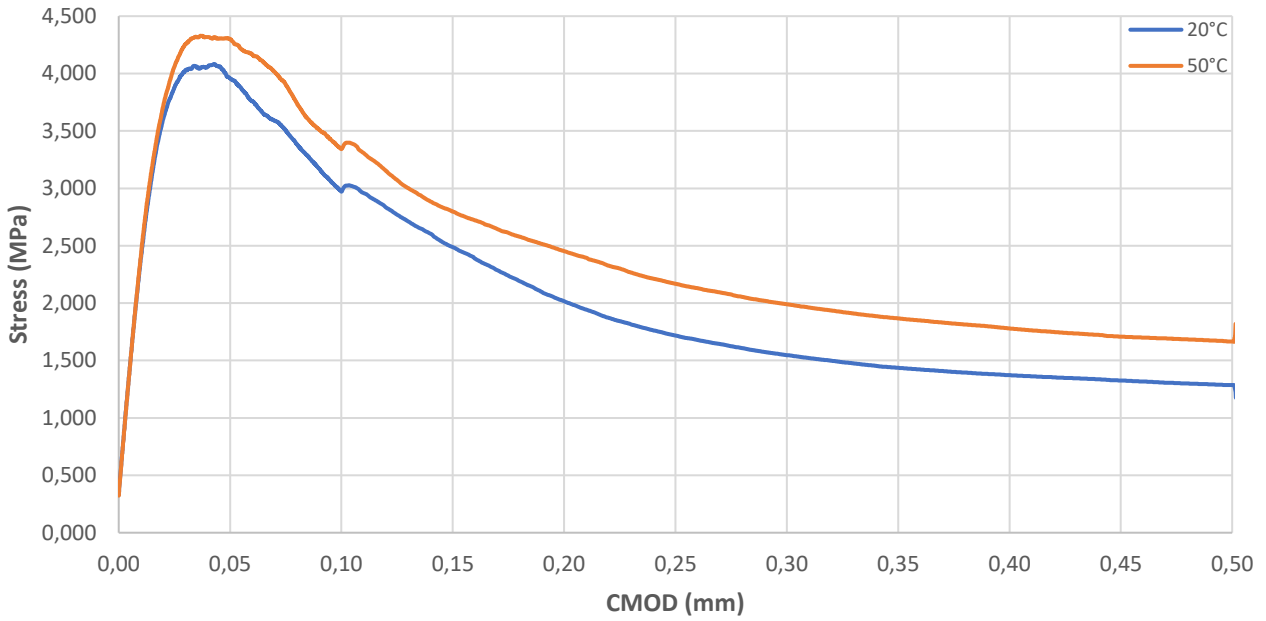

PRE-CRACK COMPARISON GRAPH FOR READYMIX - SECOND STAGE

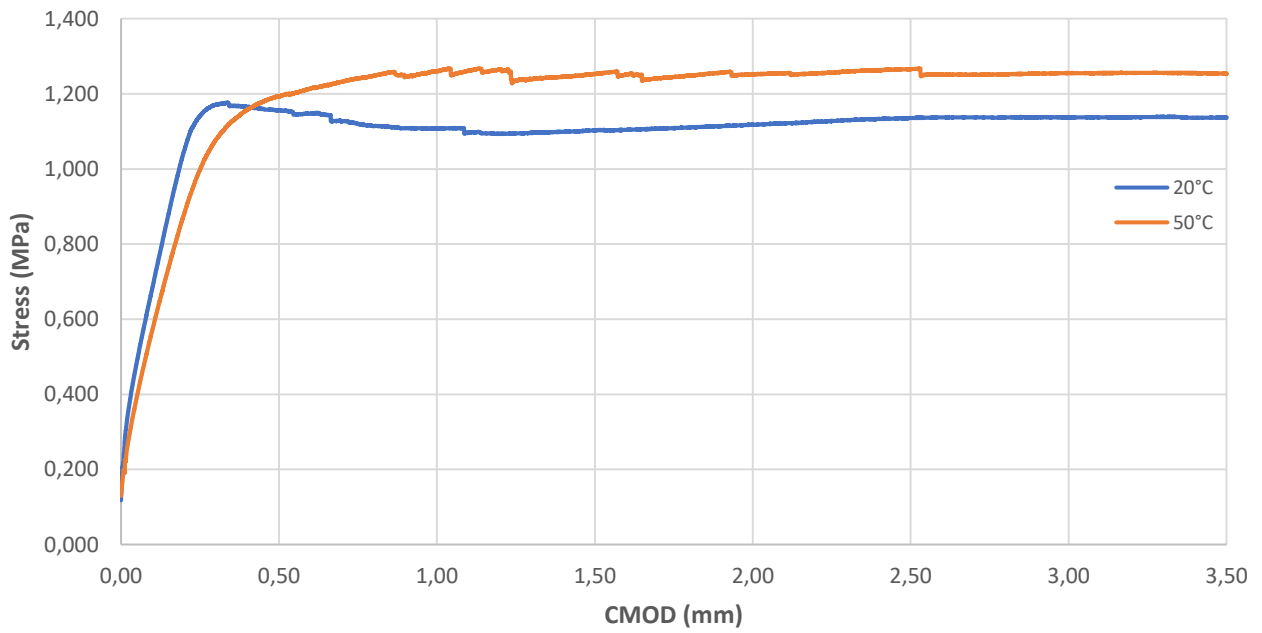

COMPARISON OF FLEXURAL STRENGTH VALUES BETWEEN READYMIX SAMPLES IN PRE-CRACK TEST

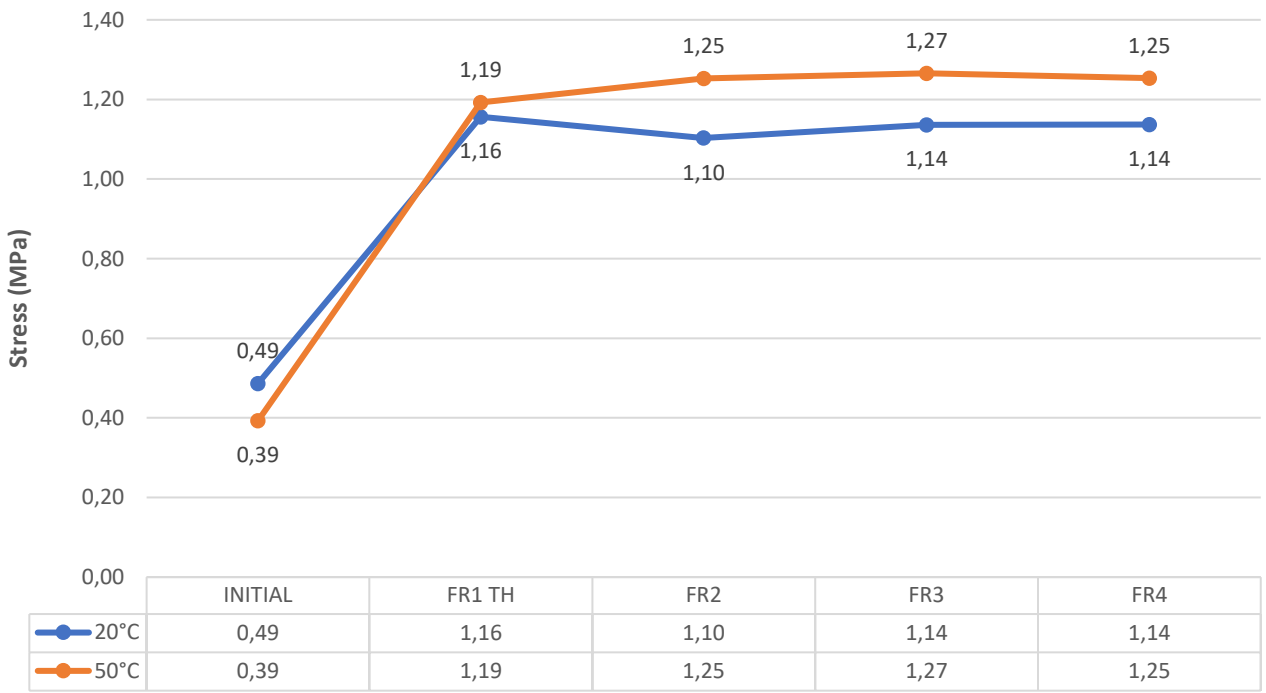

OBSERVATIONS ON READYMIX RESULTS:

RELATIVE HUMIDITY TEST

- The test has revealed that the higher is the humidity at which the sample is kept the minor is the flexural performance of the sample
- For both conditions LOP values are the same

FLY ASH ADDITION

- In the fly ash addition mix design it is noticeable a clear difference in samples tested at different temperature: the higher is the heat the lower are the flexural performance
- The LOP values are significantly higher in the colder condition

PRE-CRACK

- In the first part of this test the samples show similar performance for LOP values both at 20°C and at 50°C
- In the second part is noticeable a peak for the colder graph curve which could indicate the presence of a roll (bunch) of fibers that give a little improvement over the sample performance after the first crack
- After the first crack is an abnormal behaviour of the samples where the 20°C ones perform worse than the 50°C ones.

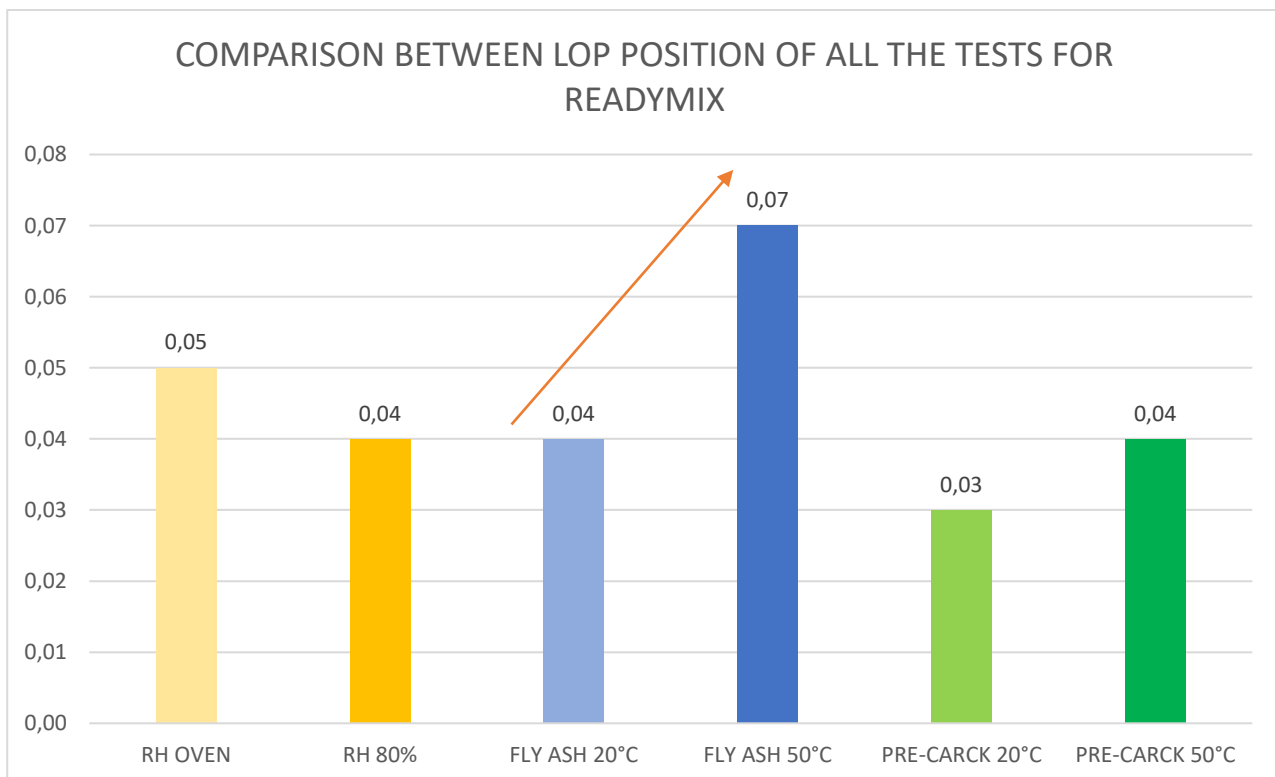

*for fly ash addition test, at higher temperature the concrete matrix has ductile behavior so it is capable of reaching major strain before cracking

5.2.2 PRECAST

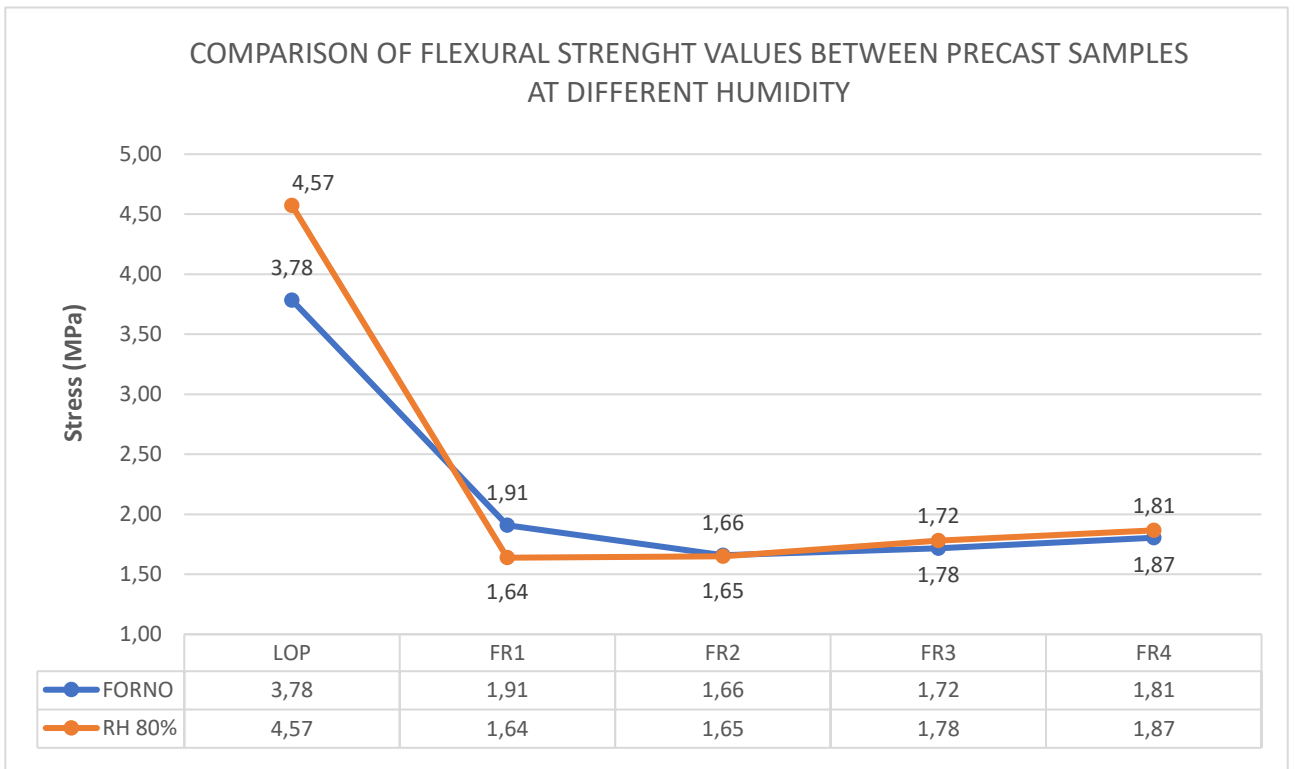
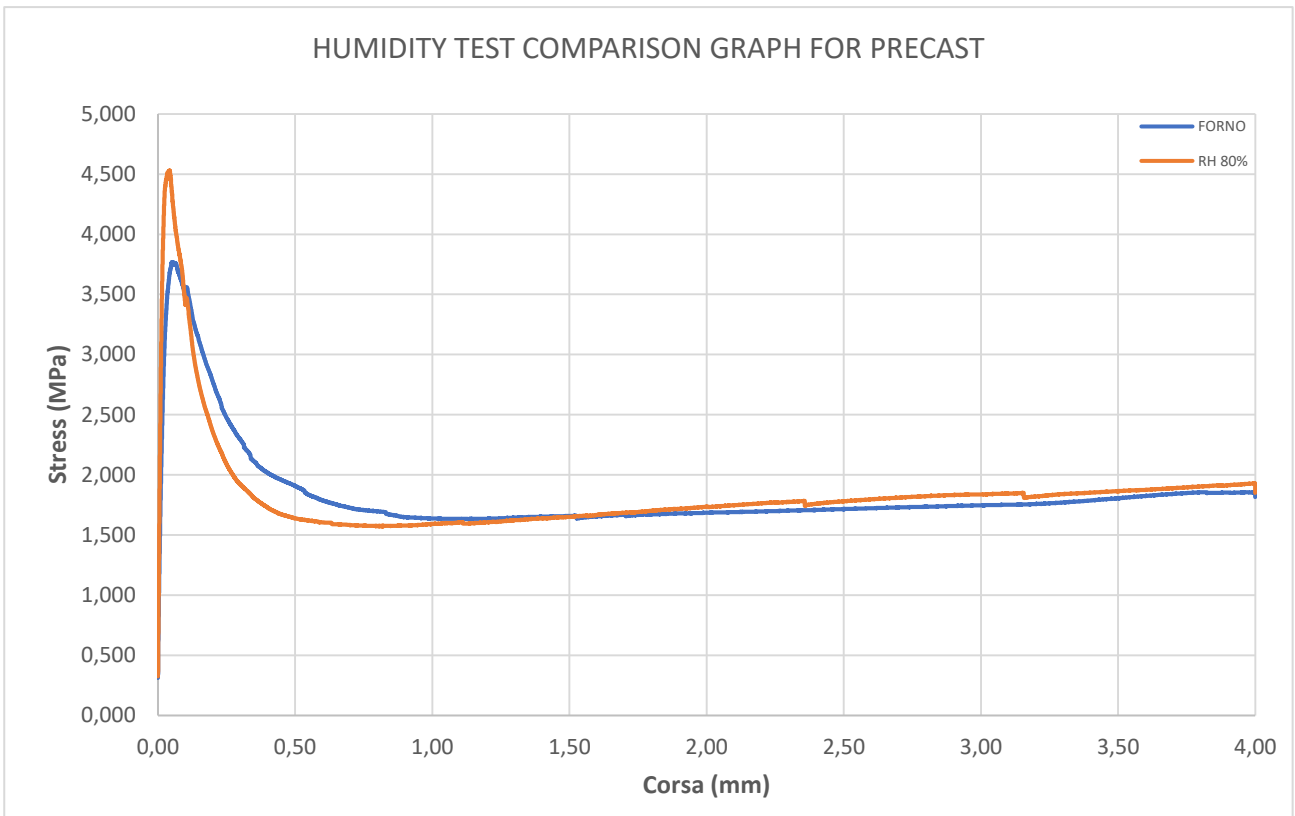

HEATING TEST COMPARISON GRAPH FOR PRECAST

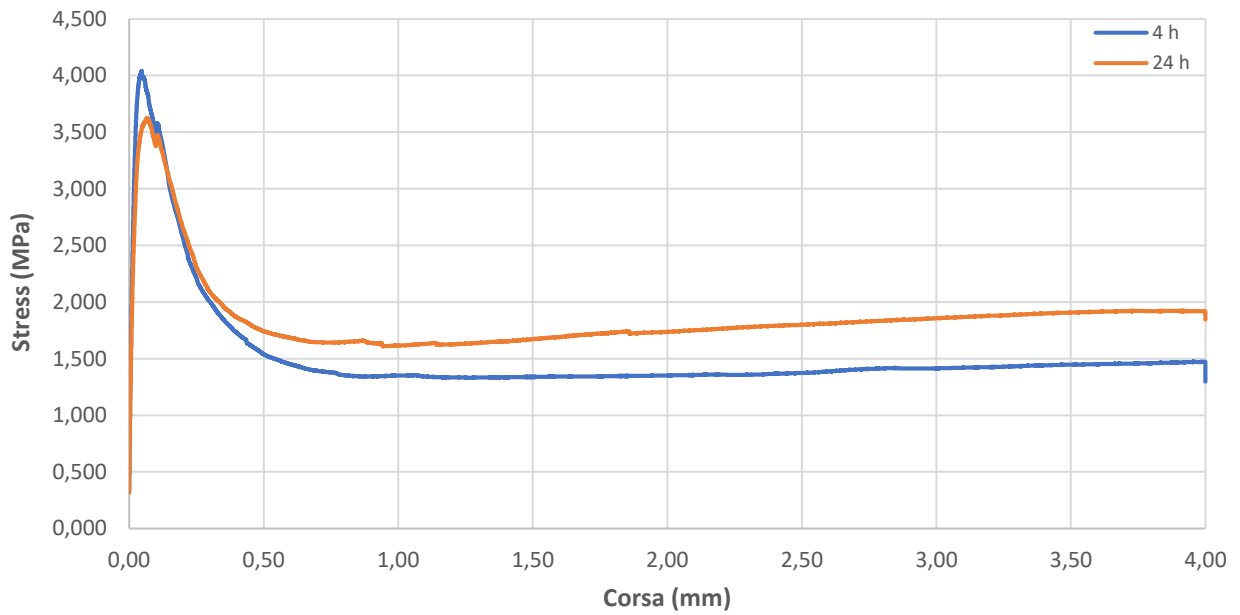

COMPARISON OF FLEXURAL STRENGTH VALUES BETWEEN PRECAST SAMPLES AT DIFFERENT HEATING TEMPERATURE

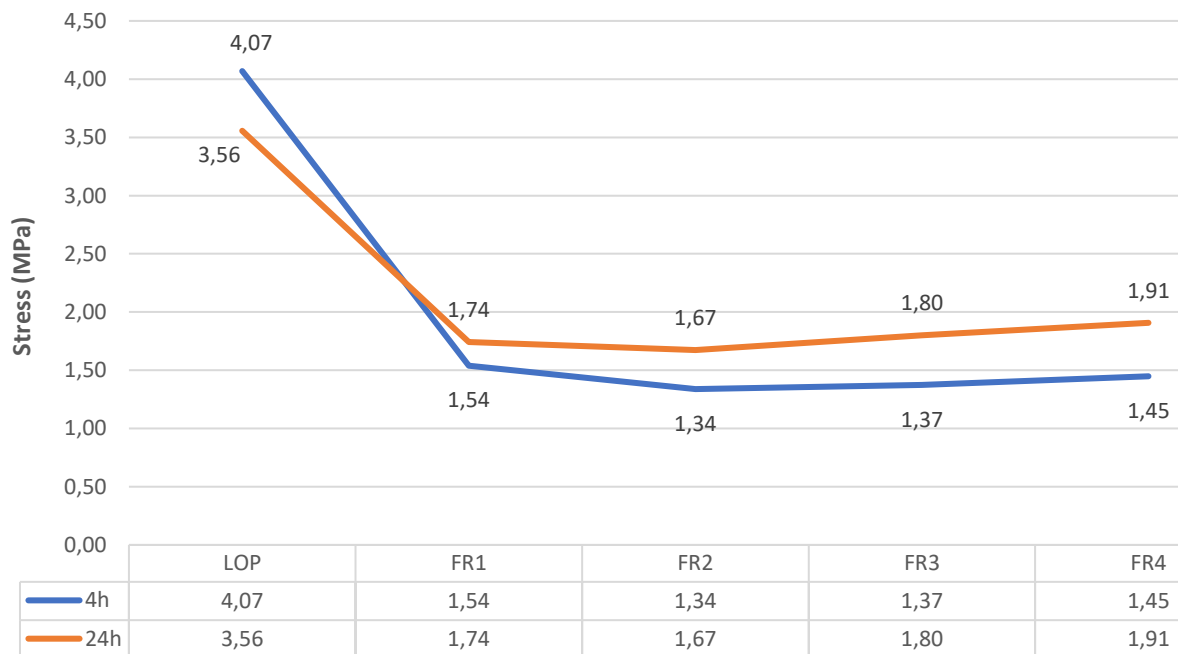

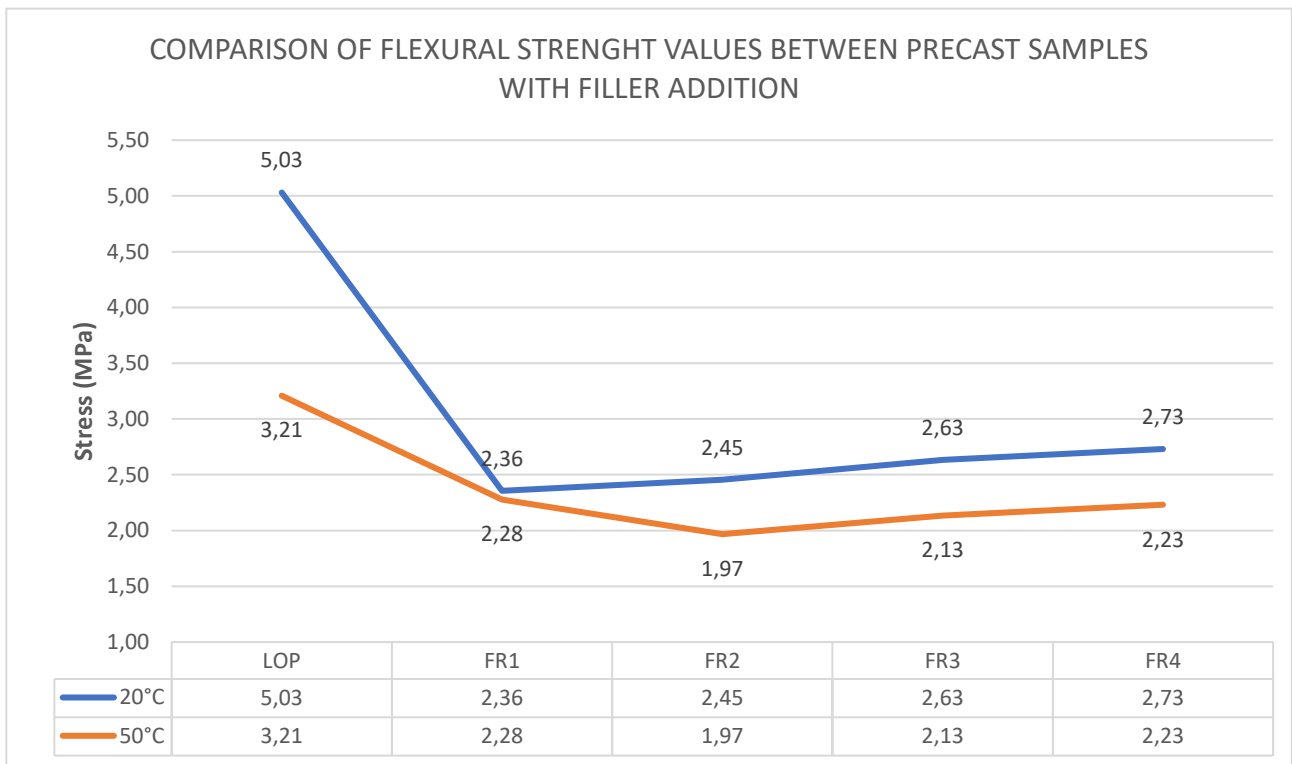
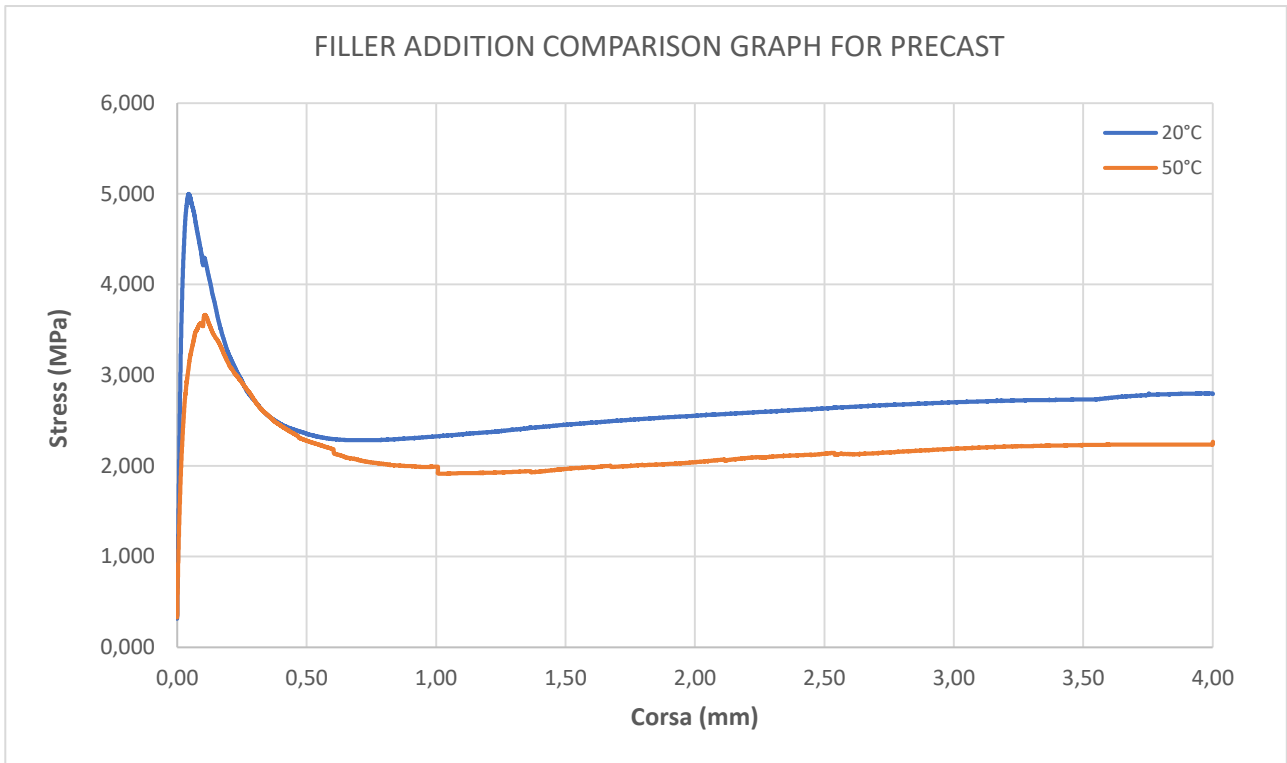

PRE-CRACK COMPARISON GRAPH FOR PRECAST - FIRST STAGE

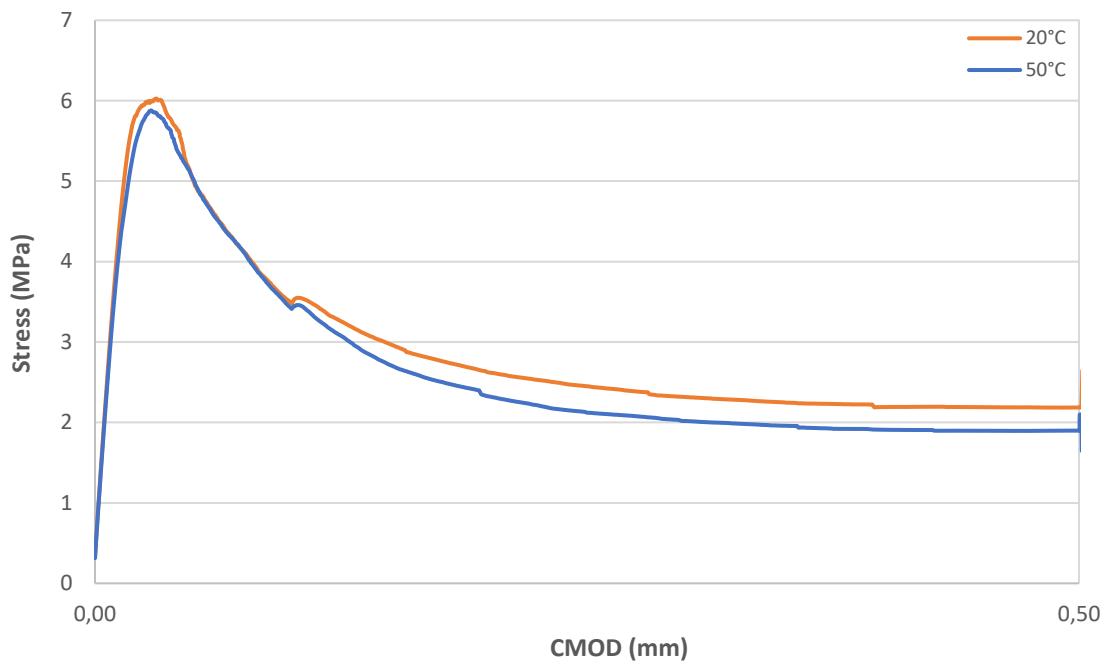

PRE-CRACK COMPARISON GRAPH FOR PRECAST - SECOND STAGE

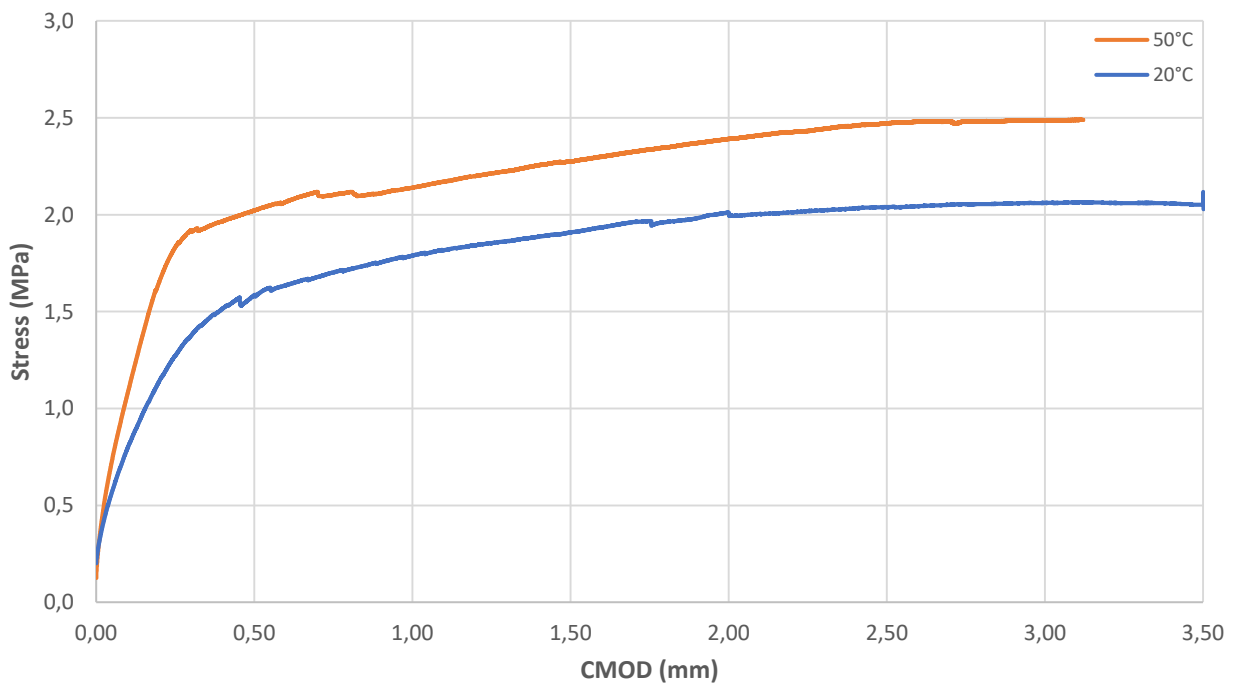

COMPARISON OF FLEXURAL STRENGTH VALUES BETWEEN PRECAST SAMPLES IN PRE-CRACK TEST

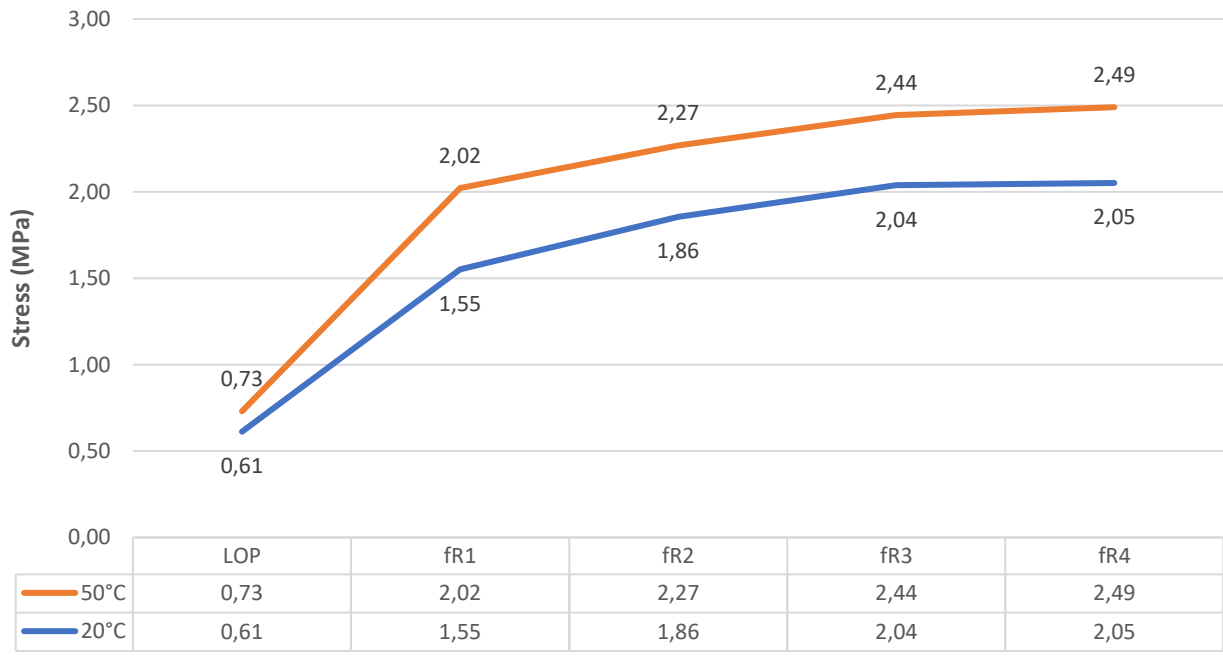

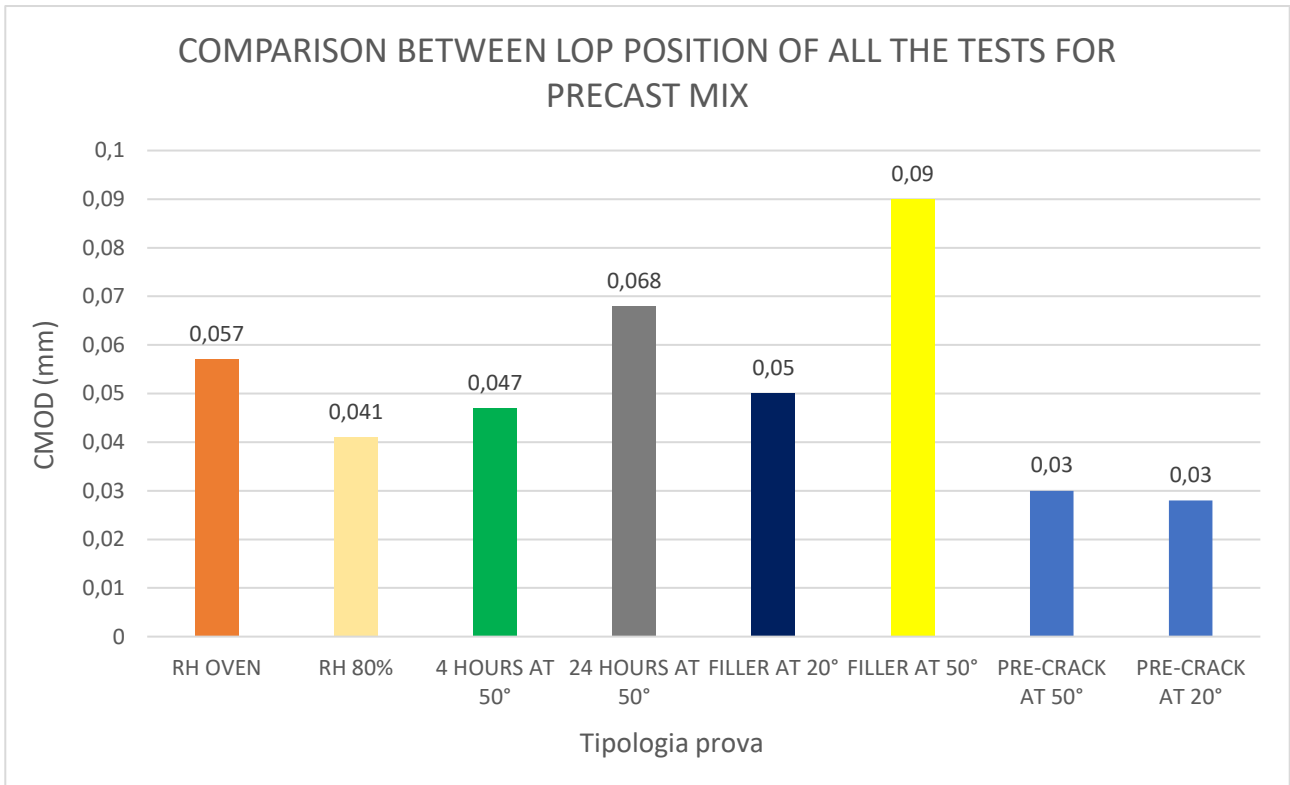

*no significant difference of LOP values across all the test conditions

OBSERVATIONS ON PRECAST RESULTS:

HUMIDITY TEST

- For precast mix design the difference in ambient humidity does not influence the flexural strength performance of concrete samples
- Only for LOP values is a slightly difference comparing the two conditions: in particular the samples at lower humidity results as most performant

HEATING TEST

- For the precast mix design the variation on heating time at 50°C is not influent on flexural performance

FILLER ADDITION

- The filler addition increases the difference between hot and cold test conditions of the sample: at 20°C the performance are clearly higher than at 50°C, with similar values of FR1 for both

PRE-CRACK TEST

- In the first part of this test the samples show similar performance in flexural strength with equal LOP values
- In the second part the hot conditions ensure better performance compared to cold conditions

5.3 PULLOUT

The pullout test data are analyzed with MINITAB software in order to better understand the correlation between all the different variables of the fibers and the force needed to pull off the single fiber from the mortar. This test is carried out without any regulation from ASTM or UNI EN ISO standards. It represents just an estimation of the fiber adhesion to the mortar matrix which is fundamental in FRC concrete materials.

5.3.1 MORTAR MATURATION OF 7 DAYS

The mortar used in this test requires at least seven days of maturation at room temperature to ensure the hydration process is complete. At this point the aggregates inside the matrix are strongly adherent to the fiber surface and is possible to measure the force required to break this bond connection.

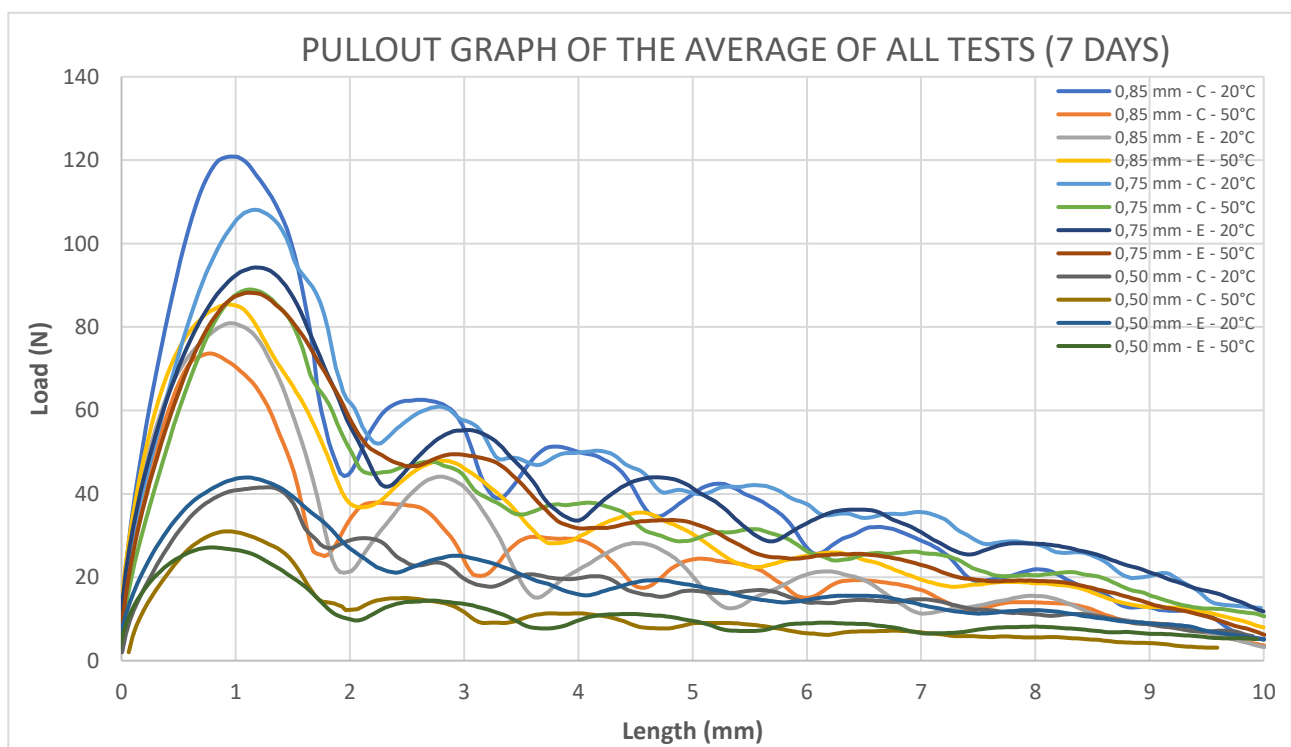

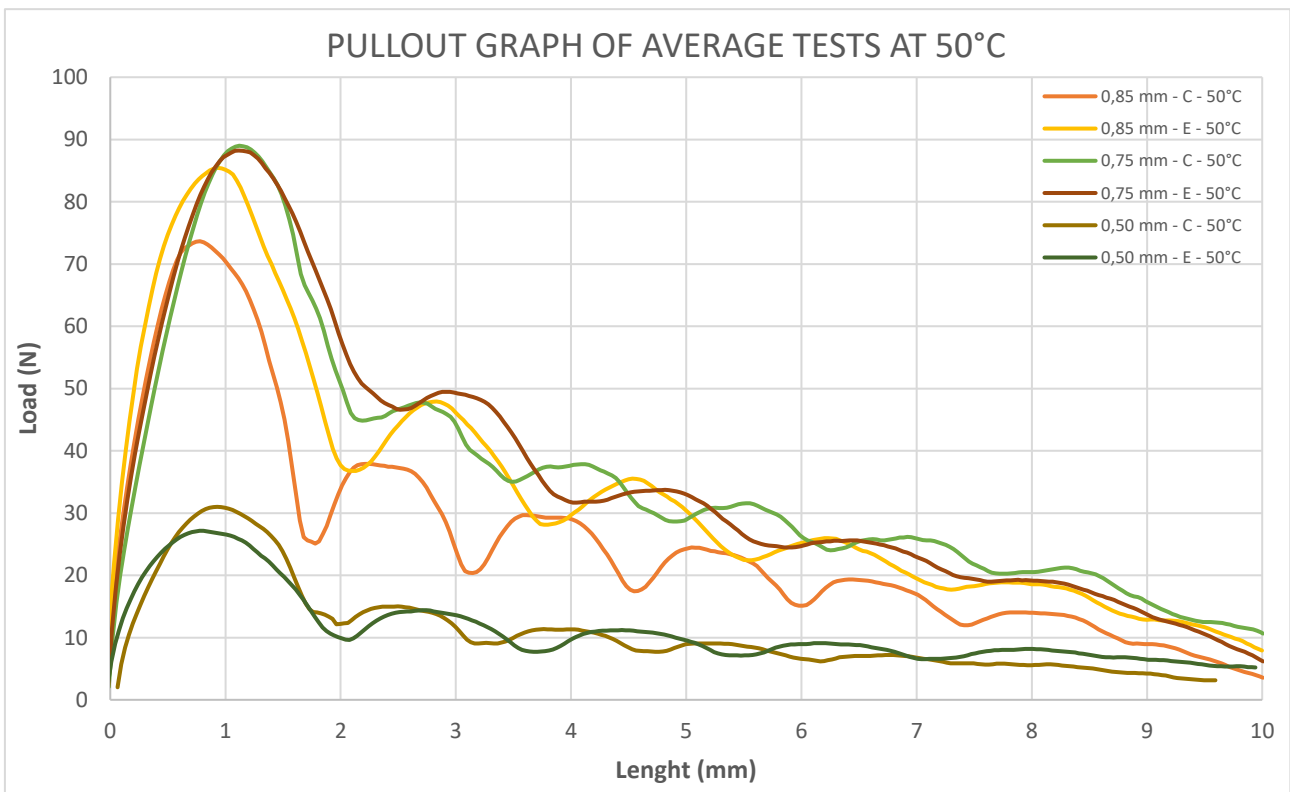
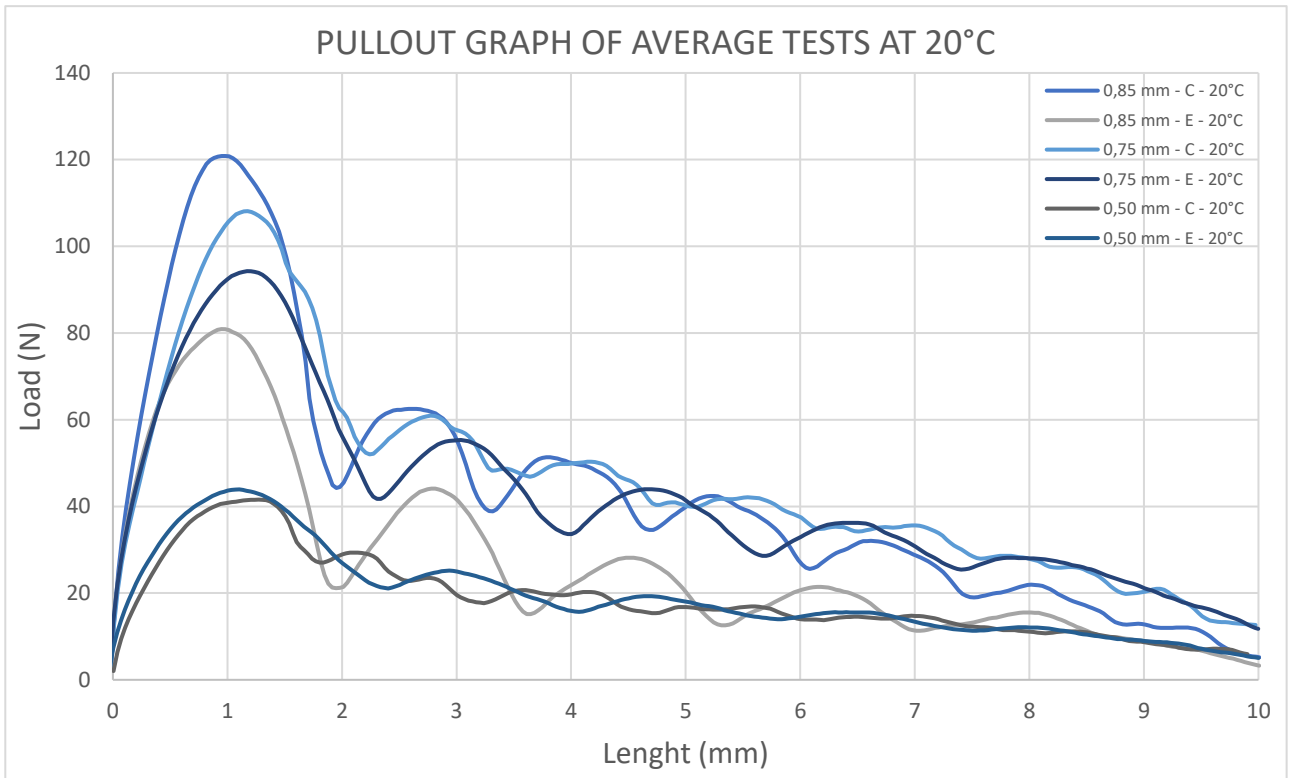

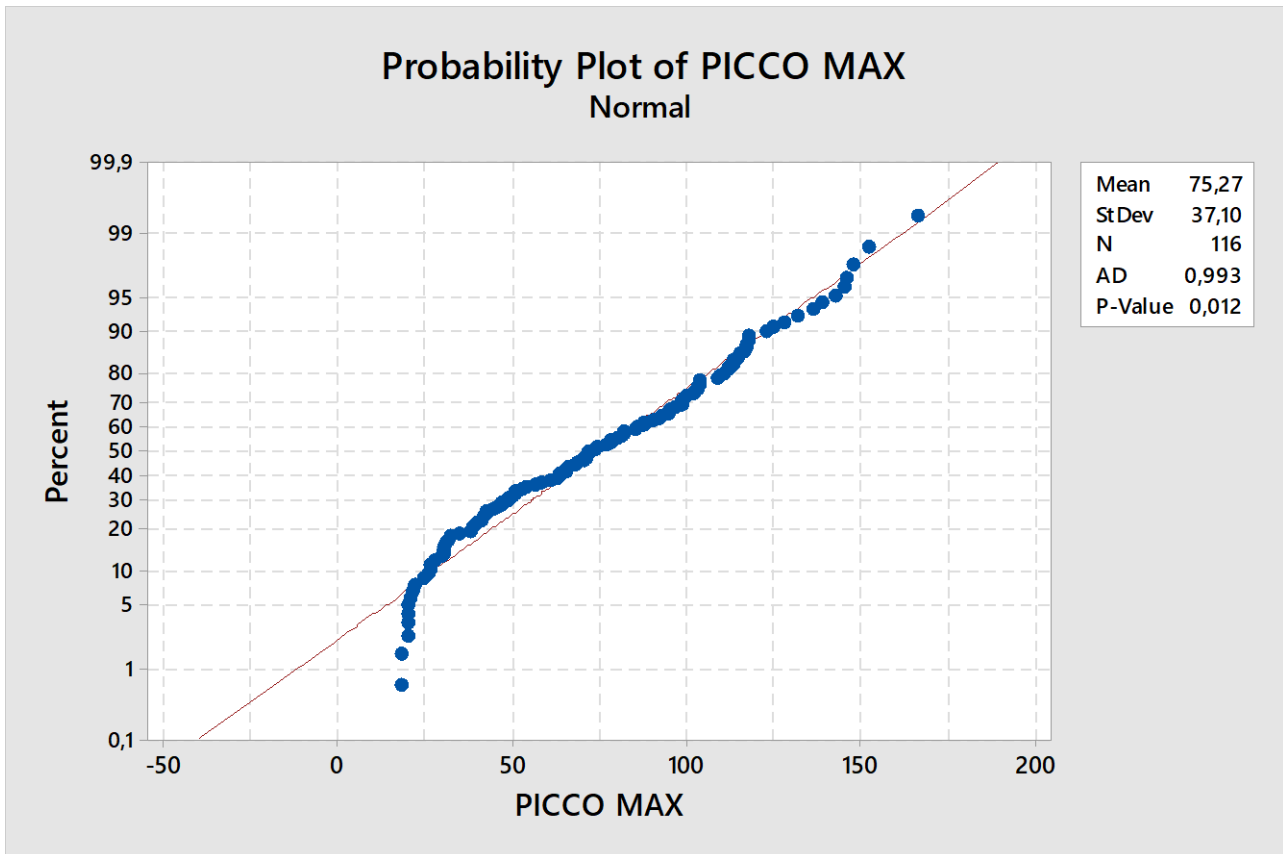

The graph above is a probability plot which is used in statistics to determine if a set of data has a normal distribution. Generally speaking, is common to use a bell curve or a histogram graph but they can result as not sufficiently specialized.

In the plot above every single dot represent one test of pullout and the straight red line in the center indicates the normally distributed data; if all the dots (or most of them) follow the line indication then the population is assumed to be normal thus the test data are reliable. With a normal probability plot, it can be easier to see individual data items that don't quite fit a normal distribution. In this case the major amount of data is good.

The following graphs are the result of the analysis for outliers in the population of samples. In particular each test is represented by a 'blue dots' on the graphs for the respective force peak. Every column of points is a set of ten samples with the same fiber characteristics:

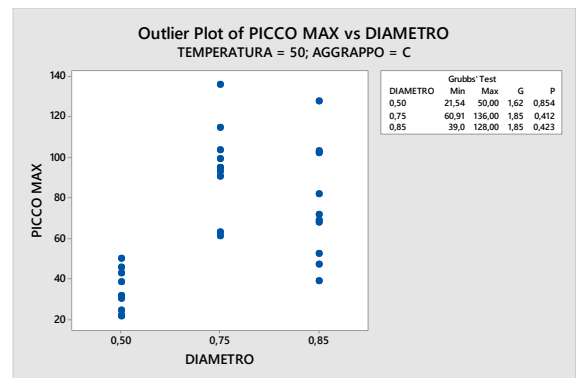
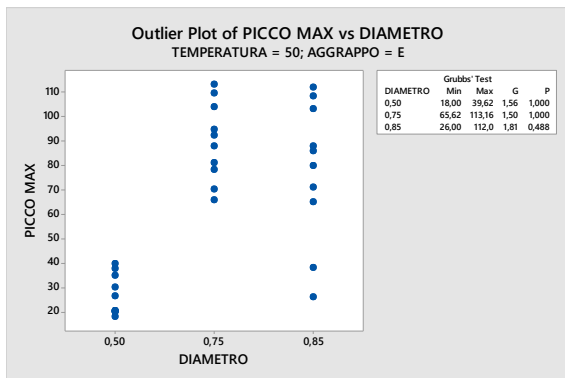
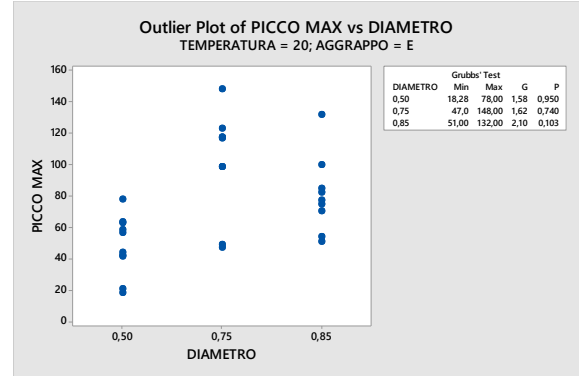
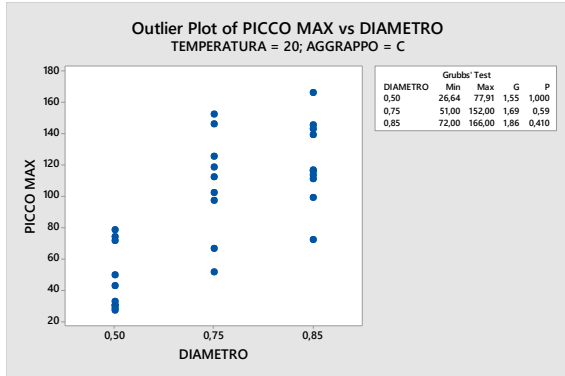

No outliers are present for this set of sample tests: eventually they would be represented by 'red dots'

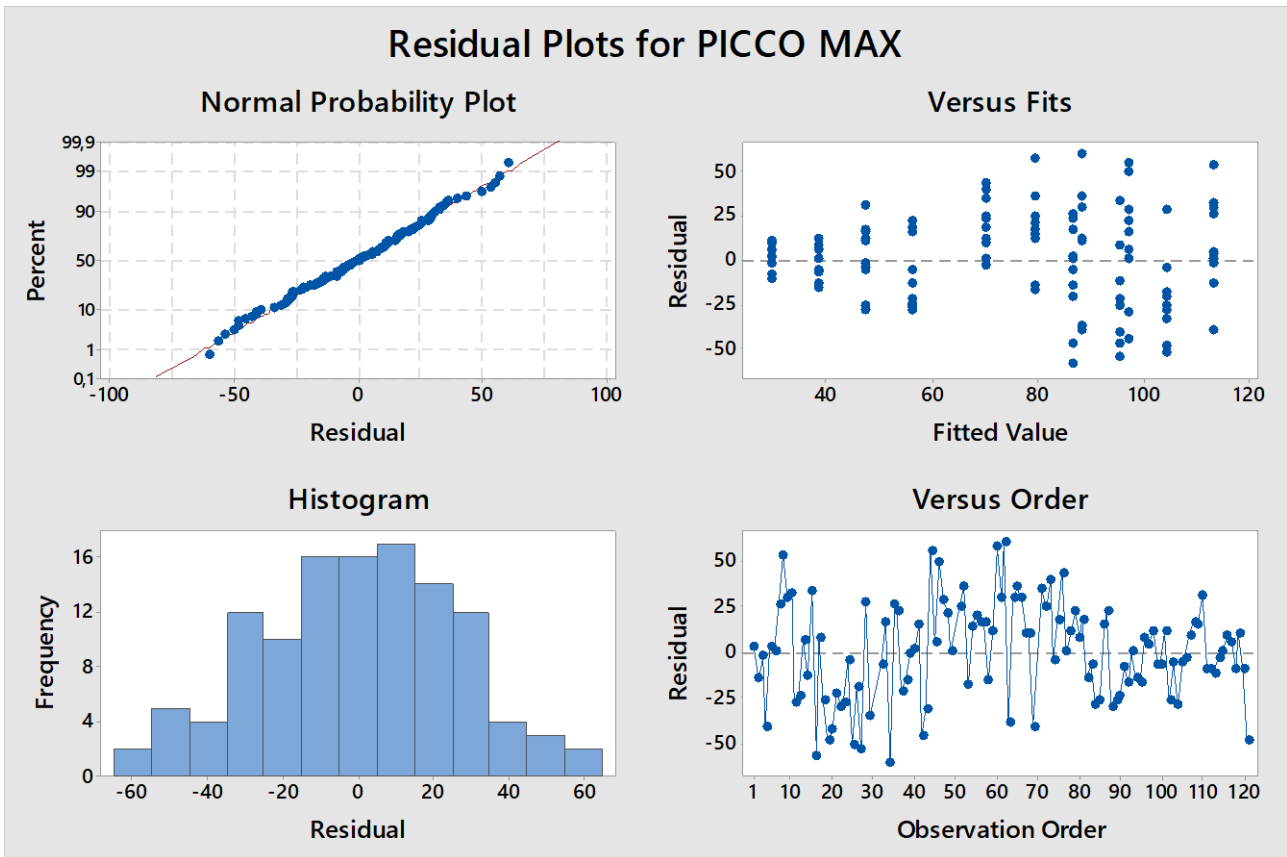

The definition of residual in statistics is the difference between the observed value of the dependent variable and the predicted value from the statistic model. A residual plot is a graph that shows the residuals on the vertical axis and the independent variable on the horizontal axis. If the points in a residual plot are randomly dispersed around the horizontal axis, a linear regression model is appropriate for the data; otherwise, a non-linear model is more appropriate.

The analysis of these charts confirms that there is not a particular dispersion of data caused by an error from the machine or the operator during the test.

Analysis of Variance					
Source	DF	Adj SS	Adj MS	F-Value	P-Value
Regression	3	79752	26584,0	37,61	0,000
DIAMETRO	1	68532	68531,8	96,95	0,000
TEMPERATURA	1	9317	9316,9	13,18	0,000
AGGRAPPO	1	2324	2324,2	3,29	0,072
Error	113	79881	706,9		
Lack-of-Fit	8	20727	2590,8	4,60	0,000
Pure Error	105	59154	563,4		



The 'p-Value', or probability test, is a number that indicates if the correspondent variable is significant for the test: if this condition is true, its p-value is below 0.05. In this case with 95% of probability the geometry of the fibers does not influence the performance of the first peak in the pullout test meanwhile diameter and temperature result as mostly determinant.

Fits and Diagnostics for Unusual Observations					
Obs	PICCO MAX	Fit	Resid	Std Resid	R
8	166,00	113,36	52,64	2,02	R
16	39,00	95,51	-56,51	-2,16	R
27	51,00	104,45	-53,45	-2,05	R
34	26,00	86,59	-60,59	-2,32	R
44	152,00	97,04	54,96	2,10	R
60	136,00	79,18	56,82	2,17	R
62	148,00	88,12	59,88	2,28	R

R Large residual

The statistic model indicates the test that are not suitable for a good fit of the data: in the 'Obs' column are listed the different test, with number of line correspondent in the table used in MINITAB to list all the test data, that limit the analysis to be as precise as possible.

Finally, the model suggests an equation to estimate the peak of the test with personalized diameter and temperature:

Regression Equation

GEOMETRY

C PICCO MAX = -13,5 + 163,3 DIAMETRO - 0,595 TEMPERATURA

E PICCO MAX = -22,4 + 163,3 DIAMETRO - 0,595 TEMPERATURA

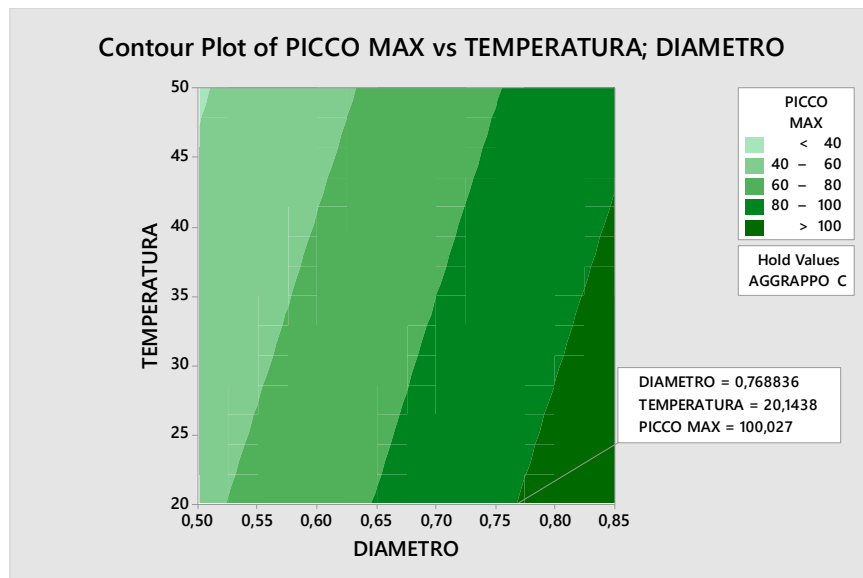

For crimping geometry, this green graph is meant to be used for selecting the right type of fiber diameter depending on the temperature of testing. If the maximum force of pullout requested is, for example, 70 Newton, thus the green zone is the second from the left.

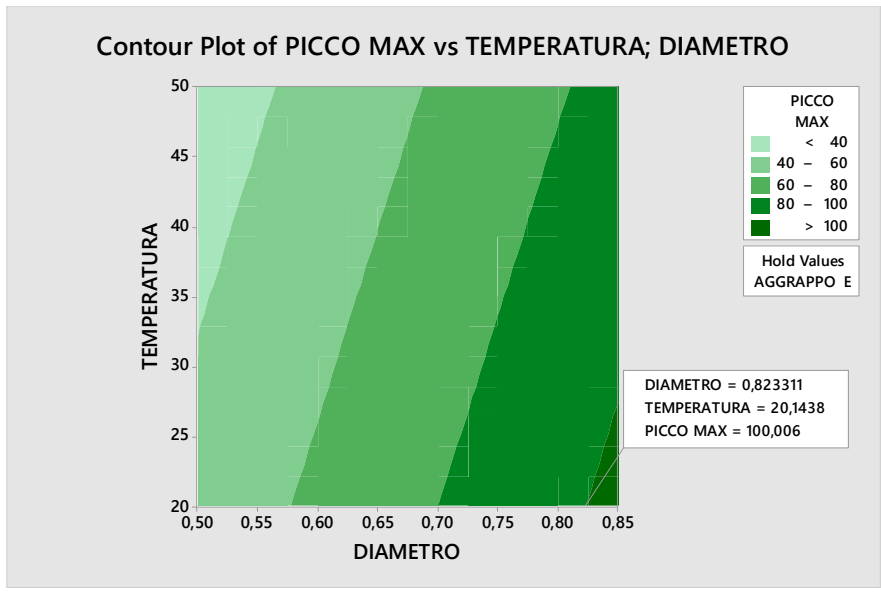

For embossing geometry, this green graph is meant to be used for selecting the right type of fiber diameter depending on the temperature of testing. If the maximum force of pullout requested is, for example, 90 Newton, thus the green zone is the second from the right.

5.3.2 MORTAR MATURATION OF 28 DAYS

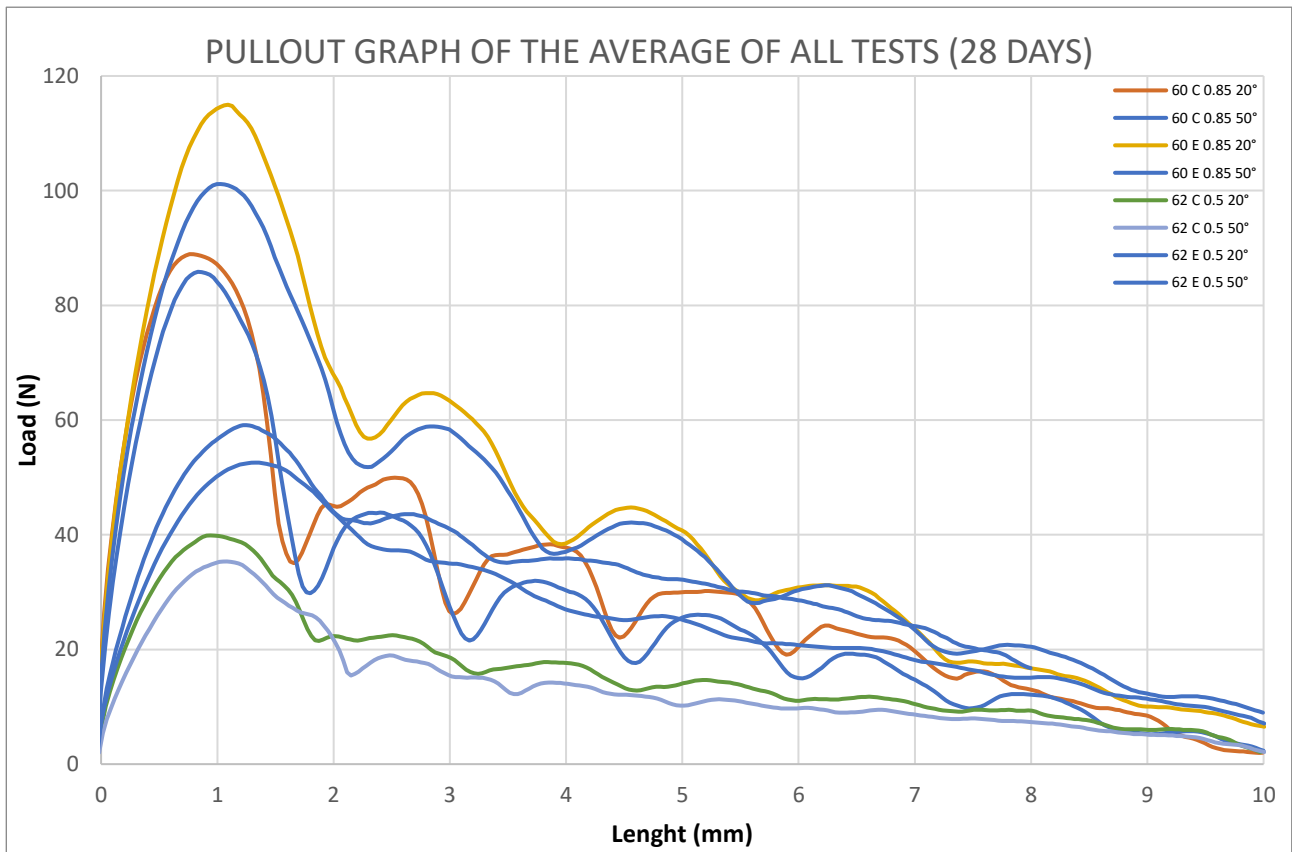

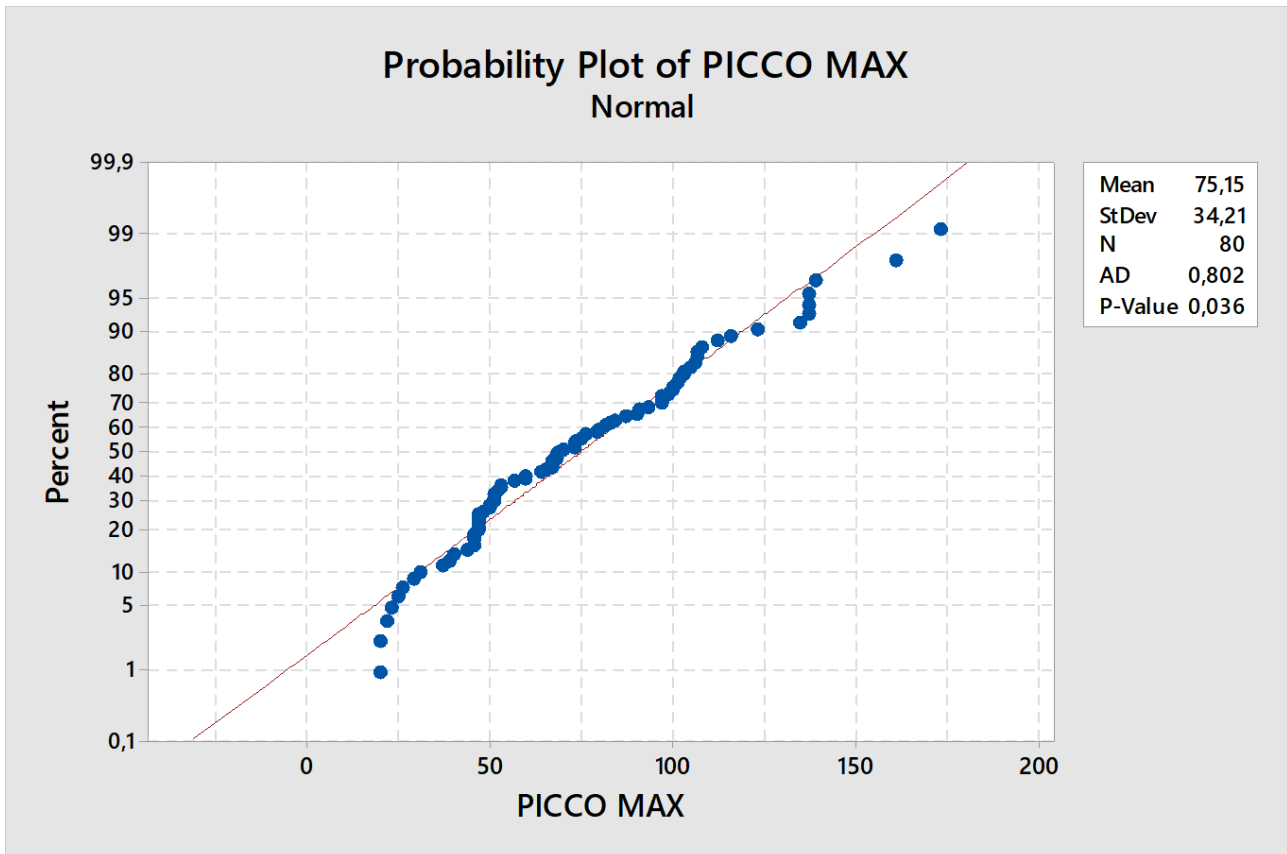

The graph above is a probability plot which is used in statistics to determine if a set of data has a normal distribution. Generally speaking, is common to use a bell curve or a histogram graph but they can result as not sufficiently specialized.

In the plot above every single dot represent one test of pullout and the straight red line in the center indicates the normally distributed data; if all the dots (or most of them) follow the line indication then the population is assumed to be normal thus the test data are reliable. With a normal probability plot, it can be easier to see individual data items that don't quite fit a normal distribution. In this case the major amount of data is good.

The following graphs are the result of the analysis for outliers in the population of samples. In particular each test is represented by a 'blue dots' on the graphs for the respective force peak. Every column of points is a set of ten samples with the same fiber characteristics:

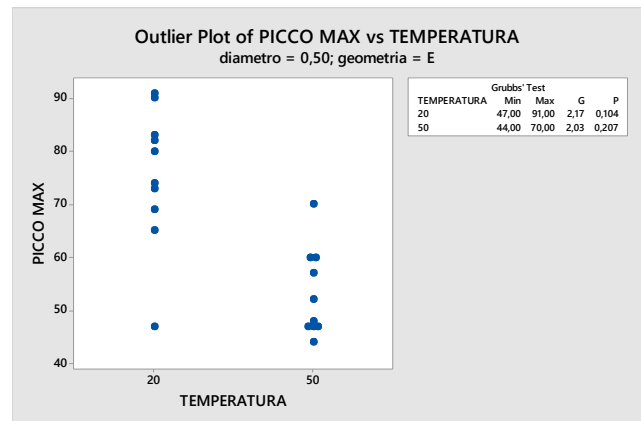
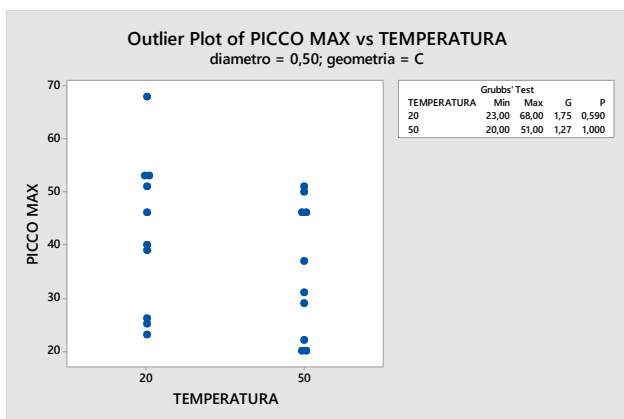
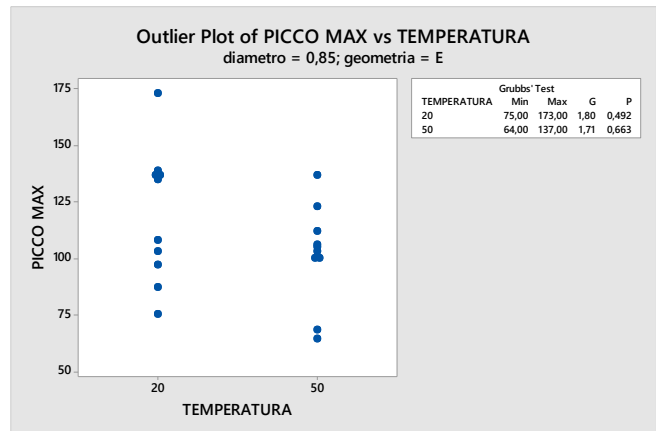
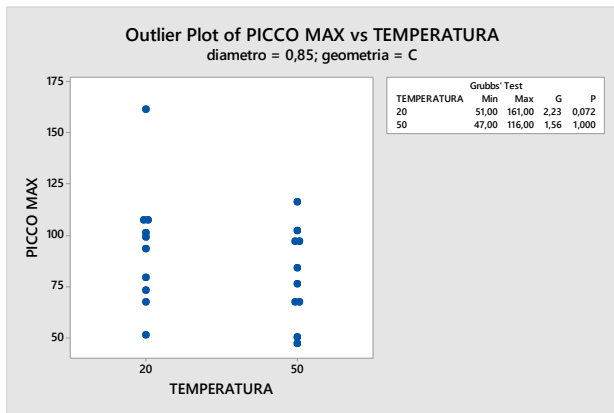

No outliers are present for this set of sample tests, despite the great dispersion of data: eventually they would be represented by 'red dots'

Residual Plots for PICCO MAX

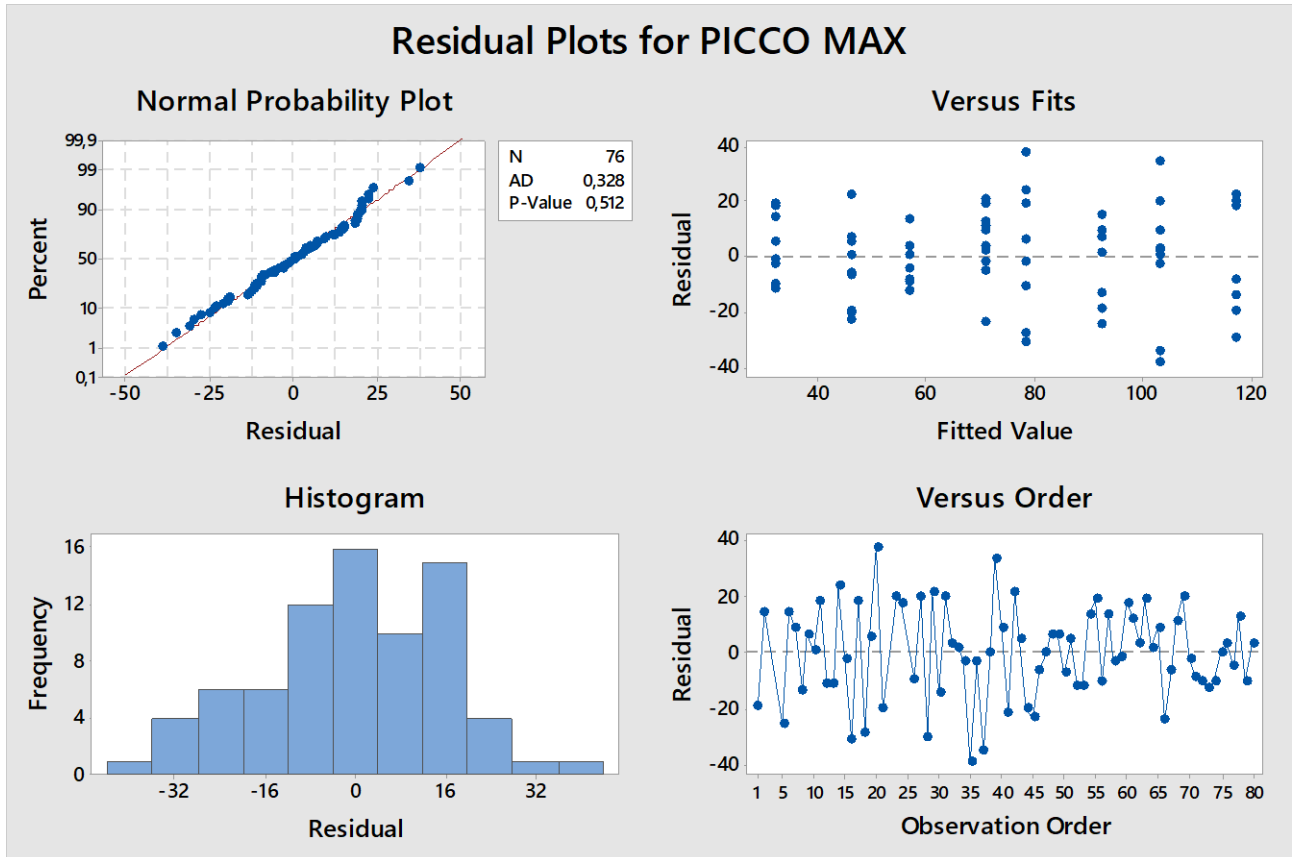

The definition of residual in statistics is the difference between the observed value of the dependent variable and the predicted value from the statistic model. A residual plot is a graph that shows the residuals on the vertical axis and the independent variable on the horizontal axis. If the points in a residual plot are randomly dispersed around the horizontal axis, a linear regression model is appropriate for the data; otherwise, a non-linear model is more appropriate.

The analysis of these charts confirms that there is not a particular dispersion of data caused by an error from the machine or the operator during the test.

Fits and Diagnostics for Unusual Observations

Obs	PICCO MAX	Fit	Resid	Std Resid	
20	116,00	78.32	37.68	2,31	R
35	64.00	103.11	-39.11	-2.40	R
37	68.00	103.11	-35.11	-2.15	R
39	137.00	103.11	33.89	2.08	R

The statistic model indicates the test that are not suitable for a good fit of the data: in the 'Obs' column are listed the different test, with number of line correspondent in the table used in MINITAB to list all the test data, that limit the analysis to be as precise as possible.

Finally, the model suggests an equation to estimate the peak of the test with personalized diameter and temperature:

Regression Equation

GEOMETRY

C PICCO MAX = -10.45 - 0,467 TEMPERATURA + 131,9 diametro

E PICCO MAX = 14,34 - 0,467 TEMPERATURA + 131,9 diametro

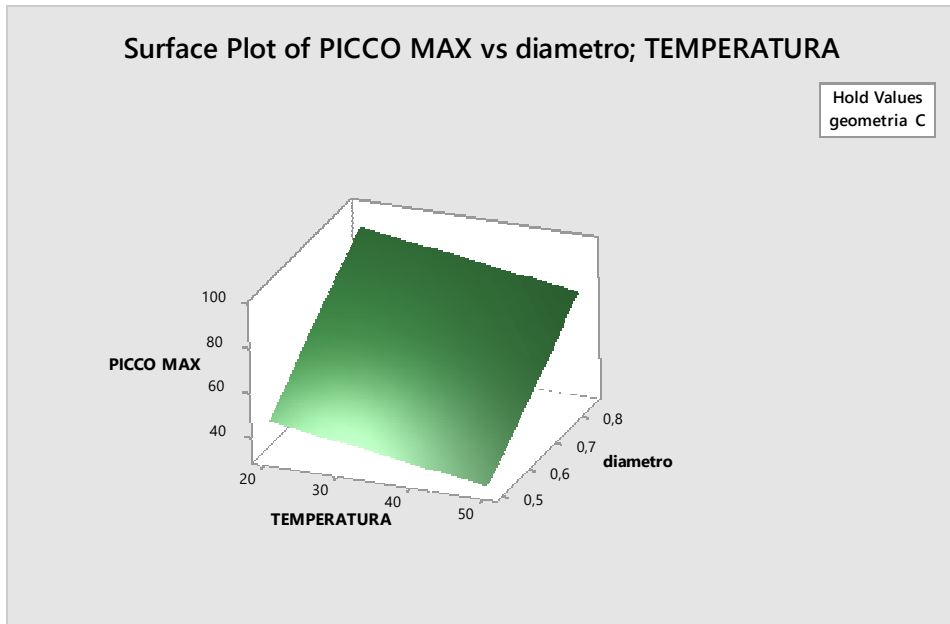
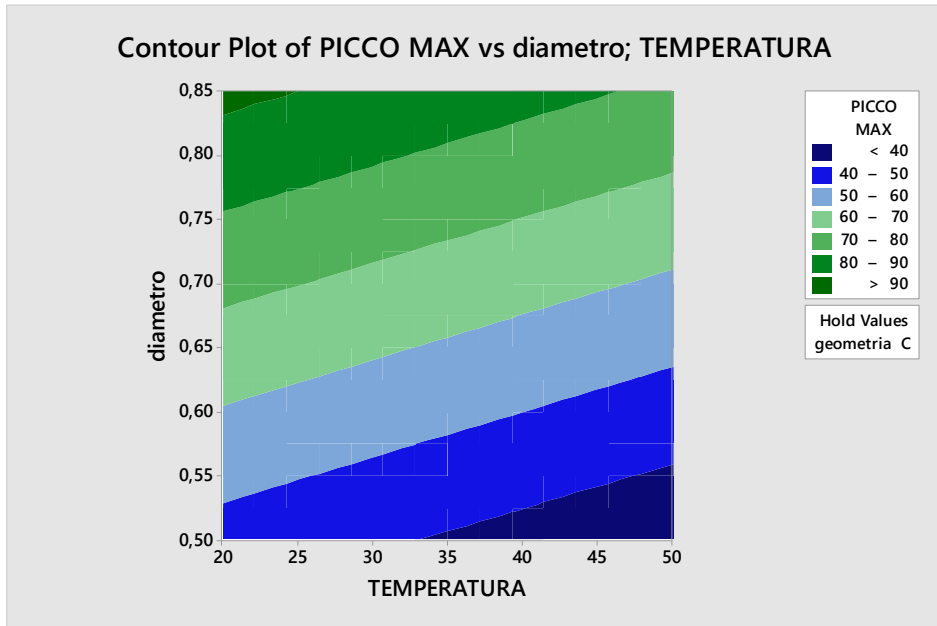

For crimping geometry, this graph with blue and green zones is meant to be used for selecting the right type of fiber diameter depending on the temperature of testing. If the maximum force of pullout requested is, for example, 50 Newton, thus the blue zone is the third from the bottom.

Contour Plot of PICCO MAX vs diametro; TEMPERATURA

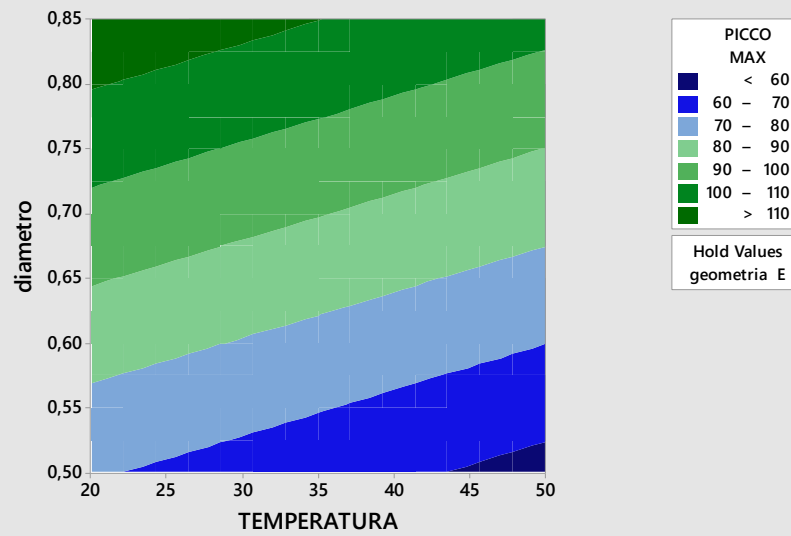

Surface Plot of PICCO MAX vs diametro; TEMPERATURA

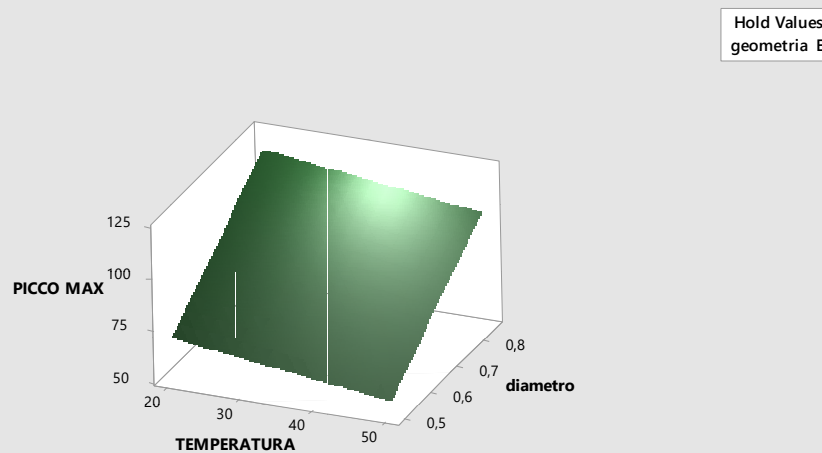

For embossing geometry, this graph with blue and green zones is meant to be used for selecting the right type of fiber diameter depending on the temperature of testing. If the maximum force of pullout requested is, for example, 95 Newton, thus the green zone is the third from the top.

Bibliography

1. *Materials and Structures/Matériaux et Constructions*, Vol. 35, November 2002, pp 579-582
2. PDF document - *basf-masterfiber spa 246 mag_2019*
3. BASF info from <https://www.basf.com/it/it/who-we-are/Le-sedi-del-Gruppo-in-Italia/Siti-produttivi/Treviso.html>
4. Fibers info from <https://www.acpresse.fr/basf-deux-nouvelles-macro-fibres-synthetiques/>
5. Fibers info from <https://www.master-builders-solutions.basf.it/it-it/products/masterfiber/masterfiber-246>
6. Mix design info from <https://www.master-builders-solutions.basf.com/en-basf/services-by-profession-group/concrete-producers/precast-producers>
7. <https://www.solidian.com/en/textile-reinforced-concrete/>
8. PDF reading 'Shells made of textile reinforced concrete-applications in germany'
9. Document 'Specifying and testing fiber reinforced shotcrete: Advances and challenges' 9/6/2017 Engineering conferences international
10. ResearchGate, Bending test setup and specimen dimensions (EN 14651)