

UNIVERSITA DEGLI STUDI DI PADOVA

---

Scuola di Ingegneria

Dipartimento di Ingegneria dell'Informazione

Corso di Laurea Triennale in Ingegneria Elettronica

Tesina di Laurea

## The solar LED street light

Relatore:

Prof. Paolo Tenti

Candidato:

Ma Hao

Luglio 2013



# Index

<b>Introduction</b>	<b>1</b>
<b>1 Solar LED Street Light</b>	<b>2</b>
1.1 Requirements on solar LED street light and significance of design.....	2
1.2 Overview of solar LED Street light .....	3
1.2.1 Basic components.....	3
1.2.2 Operation principle.....	4
1.3 Current situation and Development.....	5
<b>2 Device in solar LED street light system</b>	<b>7</b>
2.1 Solar panel.....	7
2.1.1 Working principle.....	7
2.1.2 V-I Characteristic of Solar Cell.....	8
2.1.3 Selection of solar panels.....	9
2.1.4 Power of the of solar panels.....	9
2.1.5 Installation of the solar panel.....	10
2.2 Battery .....	12
2.2.1 Selection of Battery.....	12
2.2.2 Calculation of battery capacity.....	13
2.2.3 Precautions for battery.....	14
2.3 Controller.....	14
2.3.1 Main Circuit Types.....	14
I Buck(Step-down) converter.....	14
II Boost (Step-up) converter.....	19
III Cuk converter.....	23
2.3.2 Maximum Power Point tracking (MPPT).....	26

2.3.3 Charge and discharge management.....	27
2.3.4 Automatic switch of lamp.....	28
2.4 LED.....	29
2.4.1 Principle of white LED .....	29
2.4.2 Main parameters.....	29
2.4.3 Calculate number of LED.....	31
2.4.4 Advantages and disadvantages of white LED.....	31
<b>3 Example of system design</b>	<b>33</b>
3.1 Basic meteorological and geographical conditions of Padova.....	33
3.2 Technical application.....	33
3.3 Comparison with High-pressure sodium(HPS).....	35
<b>Conclusion</b>	<b>37</b>
<b>Acknowledgment</b>	<b>38</b>
<b>References</b>	<b>39</b>

# Introduction

With the intensification of energy crisis all over the world, all the countries are looking for the way to solve this serious problem. One way is to search the new energy and take advantage of the renewable energy. Another way is to exploit the new energy-saving technologies to reduce energy consumption, and improve utilization efficiency of energy.

Solar energy is the most direct, common, and clean energy on our planet we have already found until now. Total solar energy absorbed by the Earth is about 3,850,000 exajoules (EJ) in one year, which is even twice as much as all the non-renewable resources on the earth found and used by human being, including coal, oil, natural gas, and uranium etc. The solar resources can be seemed inexhaustible.

LED is a solid state semiconductor device which can convert electrical energy into visible light. It is characterized with small size, low power consumption, long service life, environmental protection and durance. The spectrum of the LED is almostly concentrated in the visible light spectrum, so it has a high luminous efficiency which can be described as the great reform in the solid light source.

This essay briefly describes the solar led street lighting system. It uses the solar radiation energy to charge the battery with the solar panel during day time, and offer energy to the LED light equipment at night. This system has a double advantage in both utilization of new energy and energy-saving.



# Chapter 1

## Solar LED Street Light

### 1.1 Requirements on solar LED street light and significance of design

The solar street light does not need to set up the transmission line or route the cable, and no any special management and control are required. It can be installed in the entire public place such as the square, the parking lot, the campus, the street or the highway etc.

The street lighting is closely related to people's daily life. Following quick development in process of the global urbanization, the green, efficient, and long-life LED light gradually enters into our lives.

A good LED street lighting system is characterized with high efficiency, energy-saving, long-life, high color rendering index and environmental protection, which not only has a great significance on energy-saving of the city lighting , but also has close relationship with people's health and the economic development. So it is a noticeable issue how to design a reasonable LED street light system.

In my opinion, following basic requirements on a qualified solar LED street light system shall met during design process:

- (1) Learn general information of the meteorological conditions in the area.
- (2) Select the cost-effective solar panel, the controller, the battery and a series of components.
- (3) Adopt effective measures to protect the system.

These conditions ensure to design a reasonable solution and realize the significance and value of the existence of solar LED Street Light Street.

## **1.2 Overview of solar LED Street light**

### **1.2.1 Basic components**

As shown in Figure 1.2.1. The system consists of:

- (1) Solar cell
- (2) LED lamps
- (3) Light pole
- (4) Control box (charger, controller, battery)



Fig. 1.2.1 Structures of solar LED street lighting.

### 1.2.2 Operation principle

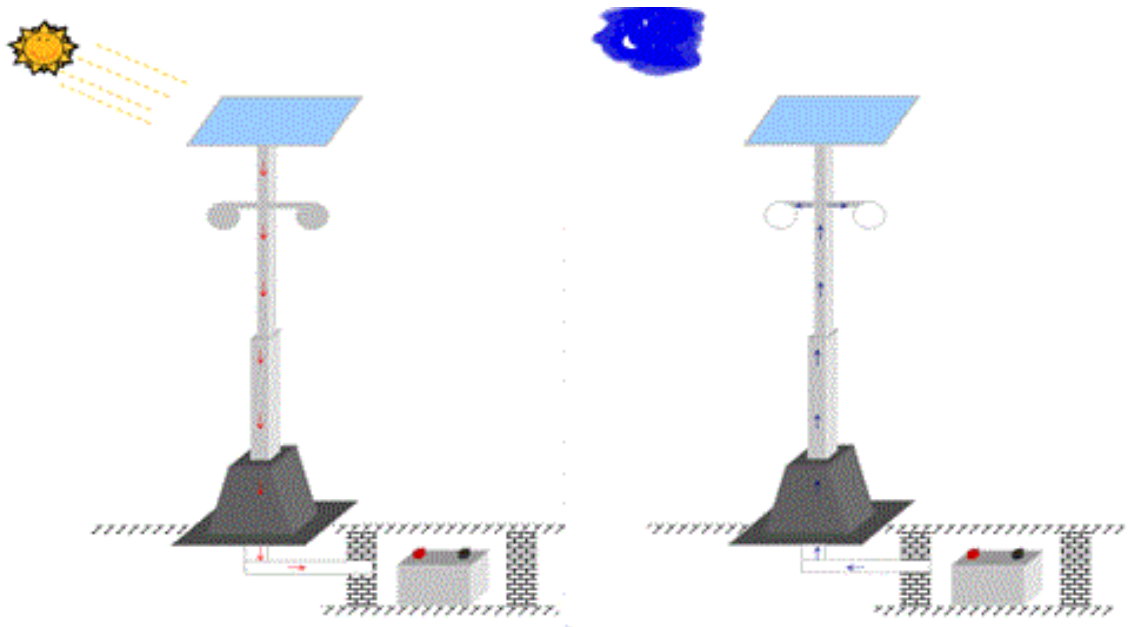

Fig. 1.2.2 Operation principle

If we can make the function of each part in Fig.1.2.2 abstractly, we can get the system workflow (Fig.1.2.3)



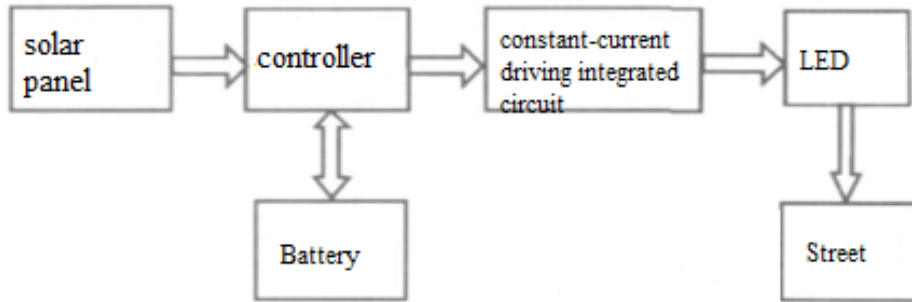

Fig. 1.2.3 System workflow

According to principle of photovoltaic effect, the solar panels receive solar radiation during the day time and then convert it into electrical energy through the charge and discharge controller, which is finally stored in the battery. When the light intensity reduced to about 10 lx during night and open circuit voltage of the solar panels reaches at a certain value, the controller has detected voltage value and then act, the Battery offer the energy to the LED light to drive the LED emits visible light at a certain direction. Battery discharges after certain time passes, the charge and discharge controller will act again to end the discharging of the battery in order to prepare next charging or discharging again.

### 1.3 Current situation and Development

From the current situation of the LED, there are still many problems which shall be further improved. For example, the quality of the LED chip, heating problem, package problem, power driver issue and the lifetime of the electronic components.

LED lighting is a developing technology although its luminous efficiency is improving and cost is continuously reduced, but it still needs long time to completely replace the traditional high pressure sodium street lighting.

Following progressing of the technology, the led lights can use more low-power

products to achieve same effect as the traditional lighting, and the price will decreased significantly in the coming year. The significant progress of the LED must make it completely replace the traditional street lights. The LED has a bright future.

## Solar Power – Block Diagram

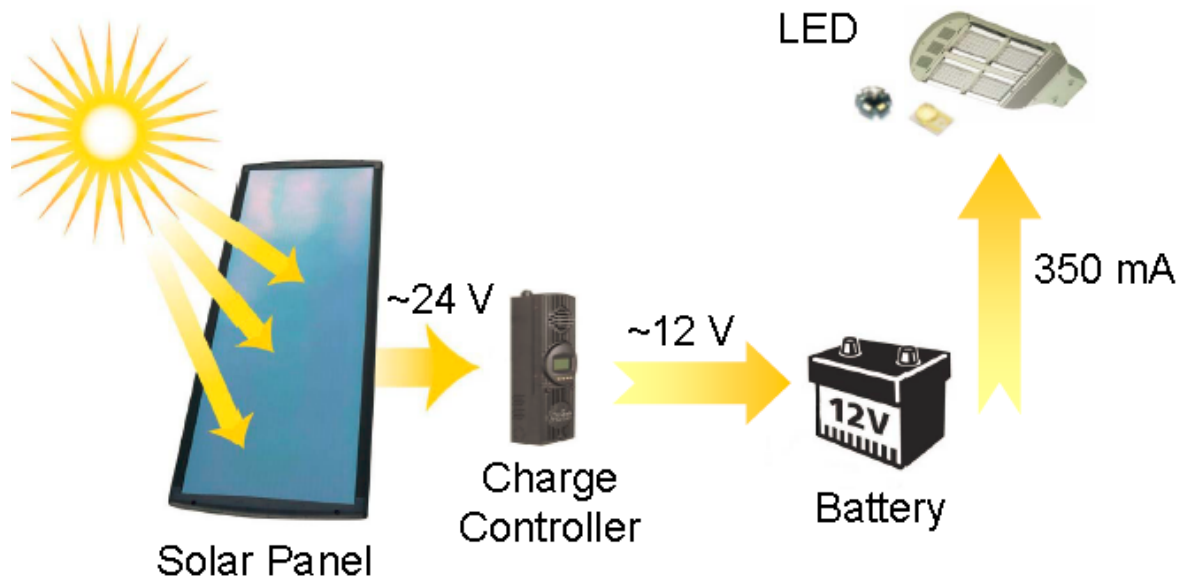

## **Chapter 2**

### **Device in solar LED street light system**

The solar street lighting system consists of many sections. In this chapter, only the Solar panel, the Battery, the Controller and the Led lights are briefly introduced.

#### **2.1 Solar panel**

##### **2.1.1 Working principle**

The Photovoltaic (PV) cell is composed of at least two layers of the semiconductors which have been “doped” with different impurities. This makes an excess of free electrons (n-type) on one side of the junction, and a lack of free electrons (p-type) on another side.

When the photovoltaic cells are irradiated with sunlight, some photons are reflected and the others are absorbed by the solar cell. When the photovoltaic cells keep enough photons, the negative electrons are released from the semiconductor material. Due to the manufacturing process of the positive layer, these free electrons naturally migrate to the positive layer which creates voltage differential.

When the solar cell is connected with the external load, there will be a current circulation in the circuit. Each single solar energy cell produces only 1-2 watts. In order to increase output power, these cells (from one to several thousands) are connected in series or in parallel with others, what is called a solar array.

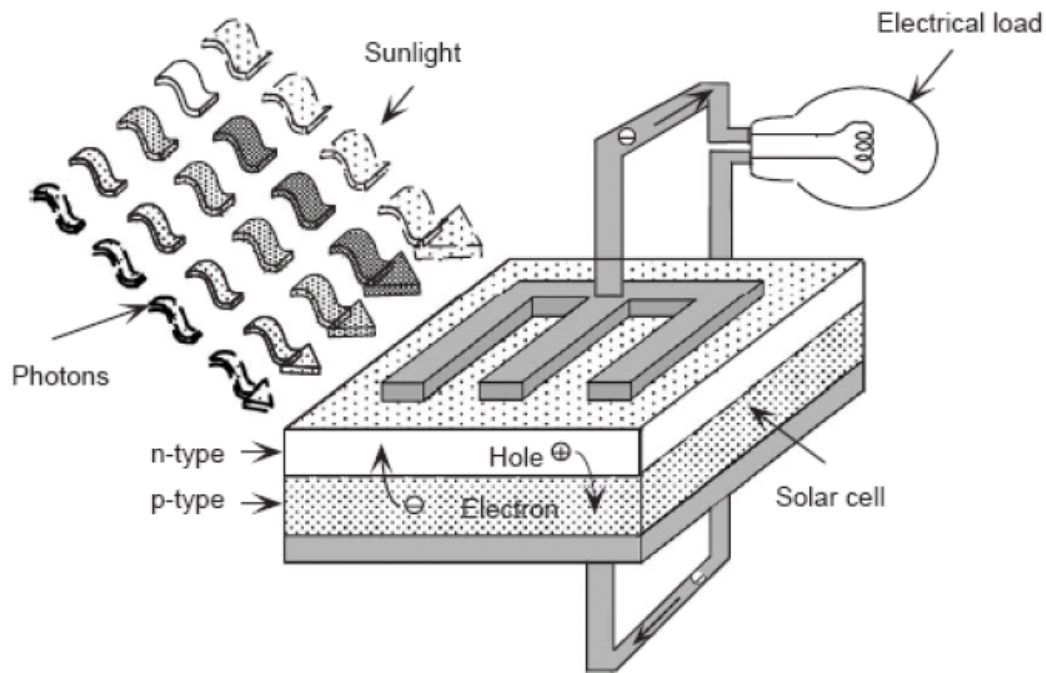

Fig 2.1.1 Principle of Solar Cell

## 2.1.2 V-I Characteristic of Solar Cell

Fig. 2.1.2 shows the V-I characteristic curve and output power of a solar panel. The curve has two parts, one indicates the trend of current with respect to increasing voltage. The other curve is the power-voltage curve and is obtained by the equation  $P=V \cdot I$ . If no load is connected with the solar panel which is working in sun light, an open-circuit voltage  $V_{oc}$  will be produced but no current follows. If the terminals of the solar panel are shorted together, the short-circuit current  $I_{SC}$  will flow but the output voltage will be zero. In both cases, when a load is connected, we need to consider V-I curve of the panel and V-I curve of the load to find out how much power can be transmitted to the load. The maximum power point (MPP) is the spot near the knee of the V-I curve, and the voltage and current at the MPP are designated as  $V_m$  and  $I_m$ . For a particular load, the maximum point is varying following insolation, shading and temperature. It is important to operate panels at their maximum power conditions.

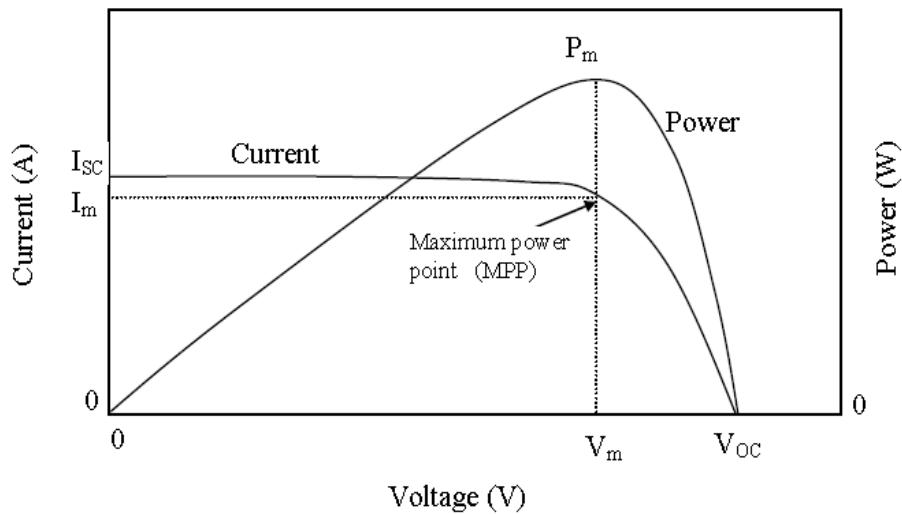

Fig. 2.1.2 V-I curve of a solar panel

### 2.1.3 Selection of solar panels

The solar panel is the core part of the solar street light system which converts the sun's radiant energy to electrical energy, and then transmits through the controller to be stored in the battery.

In sunny areas, the Polycrystalline silicon solar cell is more appropriate, because the price of the Polycrystalline silicon solar cells is lower than the Monocrystal silicon solar cells. But in the more-rainy-days areas where sunlight is relatively not very adequate; it is better to choose the Monocrystalline silicon solar cells, because the optical conversion efficiency of the monocrystalline silicon solar cells is higher.

### 2.1.4 Power of solar panels

Output power of the solar panel is random, it means output power is different at different time and places for the same piece of the solar panels. So we should consider not only the intensity of the local average solar radiation but also the daily working

hours and the power of lighting lamp during calculation of the solar panel power. .

The solar panel power can be calculated with the following equation

$$P_{(pv)} = \frac{1}{\eta_1 \eta_2} * \frac{P_{LED} * h_{LED}}{h_{(pv)}} * k \quad (2.1.3)$$

In the Formula 2.1.3:

Where:

$\eta_1$	-----	Charging efficiency of the battery
$\eta_2$	-----	Efficiency of the LED driver circuit
$P_{LED}$	-----	Power consumption of the LED (W)
$h_{LED}$	-----	Daily lighted time of Lamps (h)
$h_{(pv)}$	-----	Average of daily peak sunshine hours
$k$	-----	Loss coefficient of solar panel (for example, Dust obscured)

### 2.1.5 Installation of solar panel

The azimuth angle of the square solar cells is the angle of south direction and Vertical plane of the square, which is the direction during installation of the solar panels. In general, efficiency of the solar cell is highest when the square faces south (i.e. azimuth angle of 0 °).

The declining angle is the angle between the surface of the solar cell and the horizontal plane which is the best declining angle that the square can make the maximum generating capacity per year. The optimum declining angle is related to the local latitude and with the raise of the latitude, the inclination will also increase.

However, we should also take into account of some limiting conditions at the same of azimuth, just like the declining angle of the roof and the snow sliding. In one word, the best angle will make the daily power output reach maximum value.

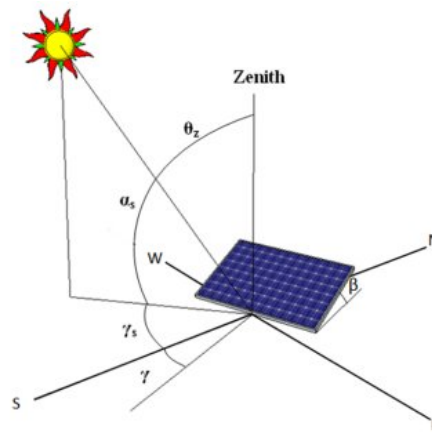

Fig. 2.1.4 Solar angles used in power calculations for PV panels.

In the Fig. 2.1.4,  $\gamma$  is Surface Azimuth Angle ,  $\beta$  is Collector Slope,

All described above are the relationship between the azimuth angle, the declining angle and the power generation amount. For the particular design of a square, we should consider all-around according to actual situations.

Furthermore, when a multi-block square solar cells is arranged, we should pay attention to impact of shadow which will decrease the generation capacity of 10% to 20%. So during arrangement of the every single square, we need adjust height to the optimum state. In snowy areas, the inclining angle of snow fall also cannot be ignored. If the optimum declining angle conflicts with the declining angle of snow, we should follow the program which can generate more electricity.

## 2.2 Battery

### 2.2.1 Selection of Battery

The requirements of the battery on the solar street light is: slower discharge rate and the long discharge time, it was decided that we usually chose the large-capacity lead-acid batteries, thus the high-energy and maintenance free valve-regulated lead-acid batteries (VRLA) is a better choice. The VRLA battery has a one-way exhaust valve (also called a valve-regulated cap) on the battery cover which can vent surplus gas in case of unusual circumstances.

The so called "maintenance-free " is regularly compared with maintenance of the traditional lead-acid battery. The VRLA batteries do not require adding water or acid during service life and it is not necessary to check the electrolyte level.

In addition, the standard to measure the quality of battery is reflected as the following aspects:

- i Long life as long as life of the system.
- ii High reserve capacity and high capacity retention rate, in order to meet the lighting needs in the consecutive rainy period.
- iii High charge acceptance efficiency which can maximize output power of the solar cell, and also shorten the charging time.
- iv Good sealing performance, no acid or gas leakage, so the battery can be set with controller.
- v Wide working temperature range (- 20°C to 50°C)
- vi Good discharge performance

The quality of the battery is directly related to performance of the streetlights.



Now there is a lot of supporting battery products on the market which are designed for the solar lighting system, we should find the appropriate battery through comparing and testing.

### 2.2.2 Capacity calculation of battery

The batteries are the main components in the solar LED street lights system, they can store energy which are generated by the solar cell during day time, and meet the power consumption of lighting at night and lighting needs in consecutive rainy days. It is not possible to meet the needs of night lighting if the battery capacity is too small. Inversely If the battery capacity is too large, we need a large solar panels to ensure the battery is fully charged in a limited time during the day . The over-large panels and battery will cause increasing of cost and also the waste. If the solar panel is not large enough, the battery can not be fully charged in limited period of time during the day, it will always be in a state of power deficit, this is a bad effect of the battery life.

The capacity of the battery can be calculated by the following formula.

$$C = \frac{Q * (D + 1)}{k_1 * (1 - k_2)} \quad (2.2.1)$$

In the formula

- C ----- Standard capacity of the battery.
- Q ----- Power consumption per day of the lamps.
- D ----- Maximum number of continuous rainy days.
- k<sub>1</sub> ----- Depth of discharge(DOD), generally the DOD of VRLA is 0.75.
- k<sub>2</sub> ----- Loss electricity of the battery's self-discharge.(10%)

### **2.2.3 Precautions on battery**

The batteries can not be directly connected in parallel, because the battery's internal resistance is different and it will form a circulation inside the batteries. So it is better to be connected in series. Moreover, a fuse must be set to protect the battery. It is also necessary to consider local weather conditions in case of excessive rainfall and in order to avoid flooding.

## **2.3 Controller**

The controller is the intelligent core of the whole solar streetlight system, it controls the entire system's normal operation and automatically prevents the battery's overcharge, or over discharge. Its basic functions must also have light control, time control and anti-reverse connection etc. The controller generally has a simple measurement function. We use the DC chopper as the main circuit and the single-chip or the low-power integrated circuits as the control circuit.

### **2.3.1 Main Circuit Type**

Currently the mainly circuit topology has Step-down(Buck) converter, Step-up (Boost) converter and Cuk converter.

#### **I Buck(Step-down) converter**

The Buck converter is also known as the Step-down chopper circuit. Its principle is shown in Fig. 2.3.1(a). It has two basic operating modes. That is Continuous Current Mode(CCM) and Discontinuous Current Mode(DCM). In CCM the output current is always greater than zero. In DCM, output current is zero in a period of time when the switch is turned off, it is a critical state between these two states, that is the current which is exactly zero at end of the switch off period. The equivalent circuit of each

state is shown in Fig 2.3.1.

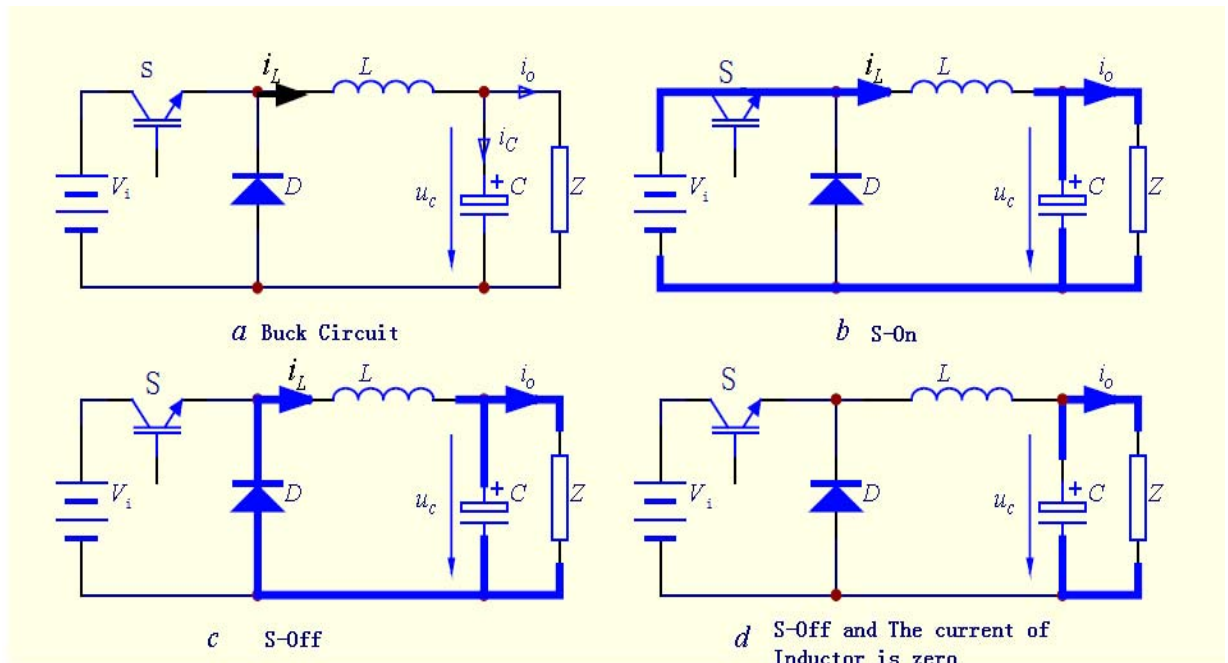

Fig. 2.3.1 Schematic diagram of Buck converter and equivalent circuit under various states of the switch

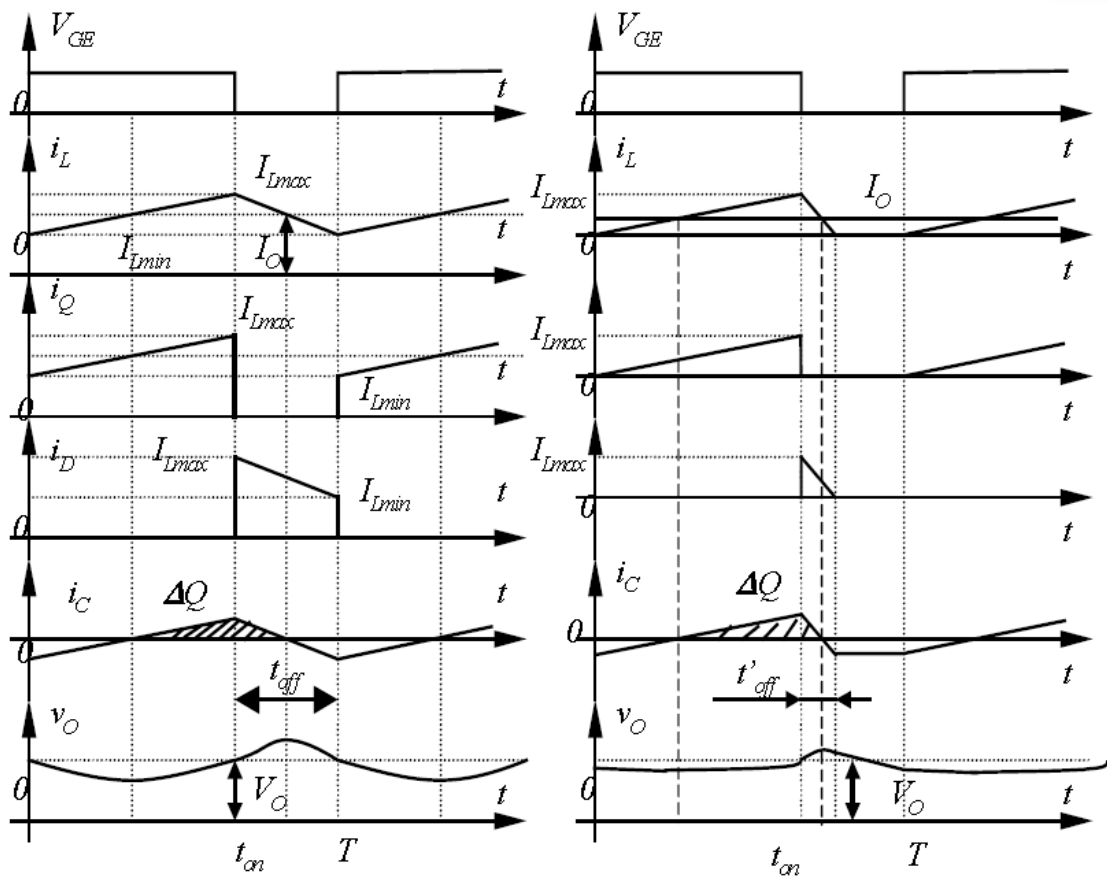

Fig. 2.3.2 Waveform in each point of Buck circuit

If we put the Square Wave signal as an input signal and the switch changes its state in a certain period, the continuity of the current in the inductor  $i_L$  depends on the switching frequency, the inductor and the capacitor. The operating waveforms of inductor current  $i_L$  under continuous conditions are shown in Fig.2.3.2.

Analysis of the circuit working under a steady state is shown as follows:

**1) Continuous Current Mode (CCM)**

**Switch Status 1:** S-on ( $0 \leq t \leq t_{on}$ )

At moment of  $t=0$ , the switch is turned on and the diode D is turned off, the equivalent circuit is shown in Fig. 2.3.1 (b). At this moment, if  $V_o$  remain unchanged during this period,

$$V_i - V_o = u_l = L \frac{di_l}{dt} \quad (2.3.3)$$

Apparently  $dt=t_{on}$  then

$$\frac{V_i - V_o}{L} dt = di_l \Rightarrow \Delta i_{l(on)} = \frac{V_i - V_o}{L} t_{on} \quad (2.3.4)$$

This is the current change in the process of switch conduction.

**Switch Status 2:** S-off ( $t_{on} \leq t \leq T$ )

At the moment of  $t=t_{on}$ , S turns off, current of the inductor which stores energy can not suddenly change, thus across the inductor L generated a opposite self-induced electromotive force(EMF) voltage to the original polarity. This EMF makes the diode D forward biased. The energy stored in the inductor is transferred to load through the

diode D. The equivalent circuit is shown in Fig.2.3.1(c), for this period  $dt=t_{off}$ , we can have

$$di_l = -\frac{V_o}{L}t_{off} \Rightarrow \Delta i_{l(off)} = \frac{V_o}{L}t_{off} \quad (2.3.5)$$

L.e. the change of current during turn-off.

Obviously, the circuit achieve balance only when increasing of inductance current during conduction period (inside  $t_{on}$ ) equals to reduction of the current during closing period ( $t_{off}$ ). By the formula 2.3.4 and 2.3.5 we can have

$$\frac{V_i - V_o}{L}t_{on} = \frac{V_o}{L}t_{off} \quad (2.3.6)$$

At last we can get

$$V_o = \delta V_i \quad (2.3.7) \quad \text{with } \delta(\text{duty cycle})=t_{on}/T$$

$$\Delta i_l = \frac{V_i - V_o}{Lf} \delta = \frac{V_o(1 - \delta)}{Lf} \quad (2.3.8) \quad \text{with } T = 1/f$$

Formula 2.3.7 shows that the average output voltage of Buck circuit is proportional to the duty cycle  $\delta$ , the duty cycle varies from 0 to 1, it means the output voltages changes from 0 to  $V_i$  and the maximum output voltage does not exceed  $V_i$ .

Because the average current in the capacitor in the switching period must be zero, if not, the value of the voltage at the end of a switching period would be different from the initial value, so we can get

$$i_c = i_l - I_o \Rightarrow I_c = I_l - I_o \Rightarrow I_l = I_o \quad (2.3.9)$$

ripple of voltage is obtained from the following expression:

$$\Delta U_c = u_c - U_o = \frac{1}{C} \int i_c dt$$

$$\Delta U_c = \frac{1}{2C} \left( I_{C_{\max}} \frac{t_{on} + t_{off}}{2} \right) = \frac{1}{2C} \frac{\Delta I_l T}{2} = \frac{\Delta I_l}{8Cf} \quad (2.3.10)$$

From 2.3.9 and 2.3.10 :

$$\Delta U_c = \frac{V_i - V_o}{8LCf^2} \delta = \frac{V_o(1 - \delta)}{8LCf^2} \quad (2.3.11)$$

We can understand that reduction of voltage is not only related to input and output voltage ,but also it increases the inductor L and the filter capacitor C can play a significant effect and raise operating frequency of the semiconductor devices can also receive the same effect. As known,  $\Delta U_c$ ,  $V_i$ ,  $V_o$  and  $f$  can determine the values of C and L according to the Formula 2.3.11.

## 2) Discontinuous Current Mode (DCM)

Fig. 2.3.14 shows the working waveform of DCM. It has three operation modes:

- ① S turns on, the inductor current  $i_L$  increases from zero to  $I_{L_{\max}}$ ;
- ② S off ,D on,  $i_L$  drops from  $I_{L_{\max}}$  to zero;
- ③ S and D are both closed, in the meantime  $i_L$  remain at zero, the load current is supplied from the capacitor.

These three operation modes correspond to three different circuit structure shown in Fig. 2.3.1(b), (c), (d).

When S is on, the inductor current growing from zero , the amount is:

$$\Delta i_l = \frac{V_i - V_o}{L} t_{on} \quad (2.3.12)$$

When S is off and the current reduces to zero

$$\Delta i_l = \frac{V_o}{L} (t_{on} + t'_{off}) \quad (2.3.13)$$

Then from 2.3.12 and 2.3.13 we can get

$$\frac{V_o}{V_i} = \frac{t_{on}}{t_{on} + t'_{off}} = \frac{t_{on} / T}{t_{on} / T + t'_{off} / T} = \frac{\delta}{\delta + \delta'} \quad (2.3.14)$$

In CCM  $\delta + \delta' = 1$ , in DCM  $\delta + \delta' < 1$ .

The output current of the converter equals to the average inductor current:

$$I_l = \frac{Q}{T} = \frac{1}{T} \frac{1}{2} \Delta i_l (t_{on} + t'_{off}) = \frac{\delta^2}{2fL} \left( \frac{V_i}{V_o} - 1 \right) V_i \quad (2.3.15)$$

The equation above indicates, on DCM mode,  $V_o/V_i$  is not only related to duty cycle  $\delta$ , but also related to load current.

## II Boost (Step-up) converter

A boost converter is also called as step-up chopper, it's a DC / DC converter with a higher output voltage of input. It can be seen from Fig. 2.3.16(a)

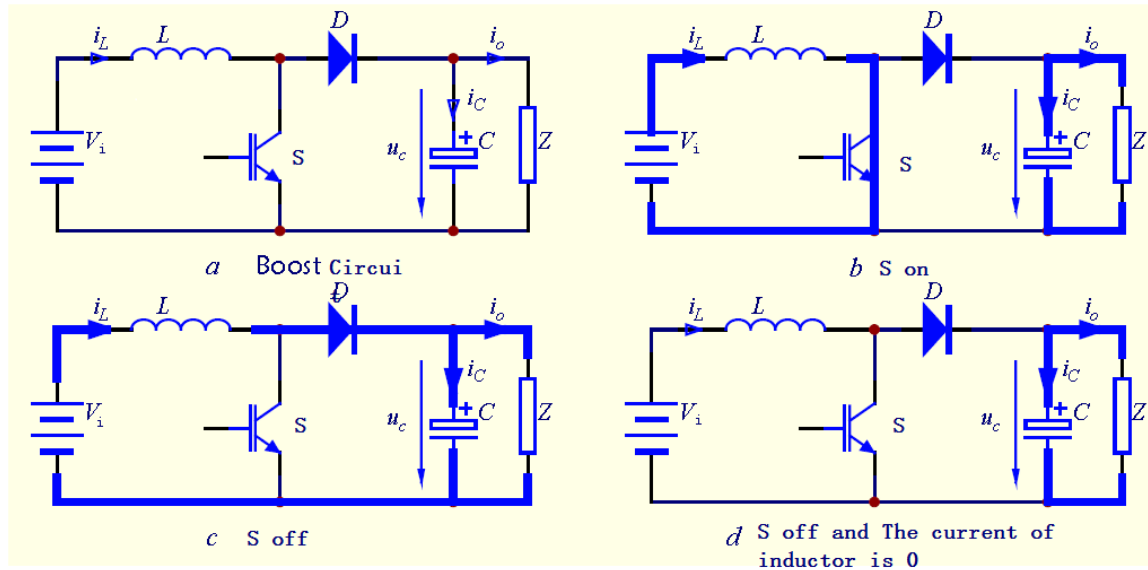

Fig. 2.3.16 Schematic diagram of Boost converter and equivalent circuit under various states of the switch

### 1) Continuous Current Mode (CCM)

**Switch Status 1:** S-on ( $0 \leq t \leq t_{on}$ )

At the moment of  $t=0$ , the switch is turned on and the diode  $D$  is turned off, the equivalent circuit is shown in Fig. 2.3.16 (b). At this moment, the current of the inductor is :

$$V_i = L \frac{di_L}{dt} \Rightarrow \frac{di_L}{dt} = \frac{\Delta i_L}{t_{on}} = \frac{V_i}{L} \quad (2.3.17)$$

And

$$\Delta i_{L(on)} = \frac{V_i}{L} t_{on} = \frac{V_i}{L} \delta T \quad (2.3.18)$$

**Switch Status 2:** S-off ( $t_{on} \leq t \leq T$ )



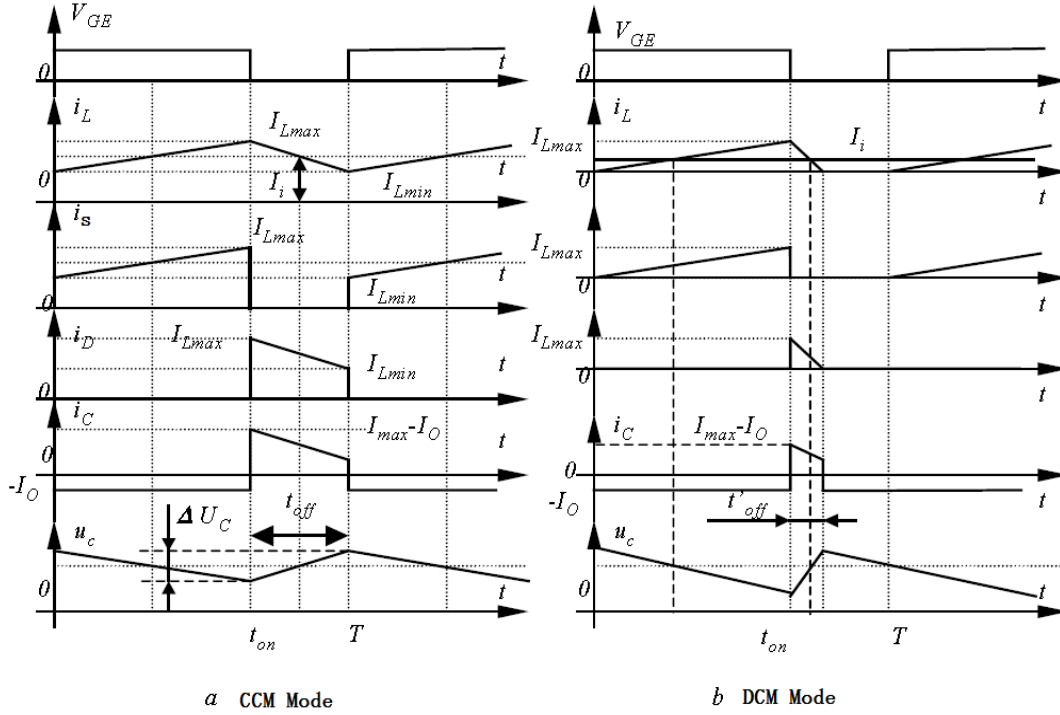

Fig. 2.3.19 Waveform in each point of Boost circuit

After the time of  $t = t_{on}$ , S turns off, the equivalent circuit is shown in Fig.2.3.16(c). The diode is forward biased. The energy of Source Power and the energy storage in L are supplied to the load and the filter capacitor C through the diode D. At this moment, voltage imposed on the inductor is  $V_i - V_o$ , the current flowing through the inductor  $i_i$ :

$$V_i - V_o = L \frac{di_l}{dt} \Rightarrow \frac{di_l}{dt} = \frac{\Delta i_l}{t_{off}} = \frac{V_i - V_o}{L}$$

$$\Delta i_{l(off)} = \frac{V_o - V_i}{L} t_{off} = \frac{V_o - V_i}{L} (1 - \delta) T \quad (2.3.20)$$

The increased inductor current in conduction period ( inside  $t_{on}$  ) must equal to ( inside  $t_{off}$  ) decrease during cut-off period. From 2.3.18 and 2.3.20 we can have:

$$\frac{V_i}{L} \delta T = \frac{V_o - V_i}{L} (1 - \delta) T \Rightarrow V_o = \frac{V_i}{1 - \delta} \quad (2.3.21)$$

Equation 2.3.21 shows that Boost converter can improve output voltage. When the duty cycle  $\delta$  varies from zero to 1, output voltage is changed from  $V_i$  to arbitrarily large.

## 2) Discontinuous Current Mode(DCM)

Similar to the Buck converter, the Boost converter has three states on DCM mode:

- ① S turns on, the inductor current  $i_L$  increases from zero to  $I_{Lmax}$ ;
- ② S turns off ,D turns on,  $i_L$  drops from  $I_{Lmax}$  to zero;
- ③ S and D are both closed, in the meantime  $i_L$  remain at zero, load current is supplied from the capacitor.

The equivalent circuit structures of these three modes during operation are shown in Fig. 2.3.16(b), (c), (d).

When S is on, the growth amount of the inductor current is:

$$\Delta i_{l(on)} = I_{lmax} = \frac{V_i}{L} t_{on} \quad (2.3.22)$$

After S turns off, the inductor current  $i_L$  decreases linearly from  $I_{Lmax}$  and at the moment  $t = t_{on} + t'_{off}$  drops to zero, that's:

$$\Delta i_{l(off)} = I_{lmax} = \frac{V_o - V_i}{L} t'_{off} \quad (2.3.23)$$

Then  $\Delta i_{l(on)}$  must equals to  $\Delta i_{l(off)}$ , from 2.3.22 and 2.3.23 we can obtained the ratio of  $V_i$  and  $V_o$  in Formula 2.3.26 , and in the formula  $\delta' = t'_{off}/T$

$$\frac{V_o}{V_i} = \frac{t_{on} + t'_{off}}{t'_{off}} = \frac{\delta + \delta'}{\delta'} \quad (2.3.24)$$

The converter works on DCM mode if  $\delta' < 1 - \delta$ , so we can make  $t'_{off} = t_{off}$  to get the average output current( $I_o = I_D$ ) of critical state.

$$\begin{aligned}
1 \dots I_{l_{\max}} &= \frac{V_i}{L} t_{on} \\
2 \dots \frac{V_o}{V_i} &= \frac{t_{on} + t_{off}}{t_{off}} = \frac{1}{1 - \delta} \rightarrow I_o = \frac{V_i}{2Lf} (1 - \delta) \delta \quad (2.3.25) \\
3 \dots I_o &= I_D = \frac{I_{l_{\max}} t_{off}}{2 T}
\end{aligned}$$

### III Ćuk converter

The Ćuk converter is named after Slobodan Ćuk of the California Institute of Technology, who firstly presented the design. It uses a capacitor as its main energy-storage component, which isn't similar to most other types of the converters with an inductor. This converter uses the two inductors, one in the input terminal, another is in the output terminal, which thereby reduces the current pulse. The circuit of the Ćuk converter is shown in Fig. 2.3.26.

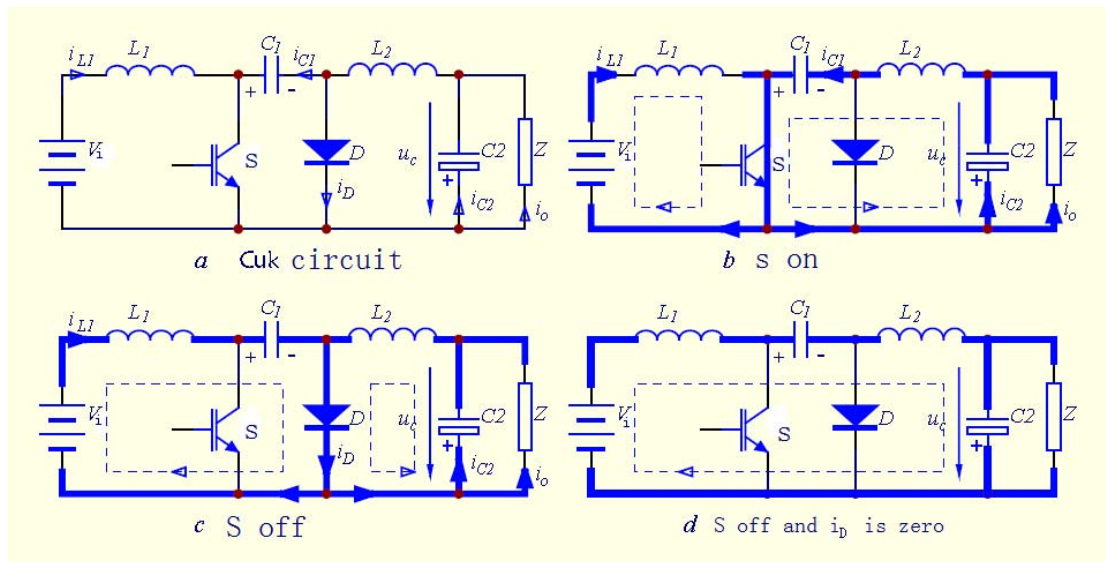

Fig 2.3.26 Circuit schematic of Ćuk and equivalent circuit

The Ćuk converter can have opposite polarity between input and output, output voltage can be higher or lower than the input voltage, and its input and output currents

are continuous. In CCM, operating waveforms is shown in Fig. 2.3.27

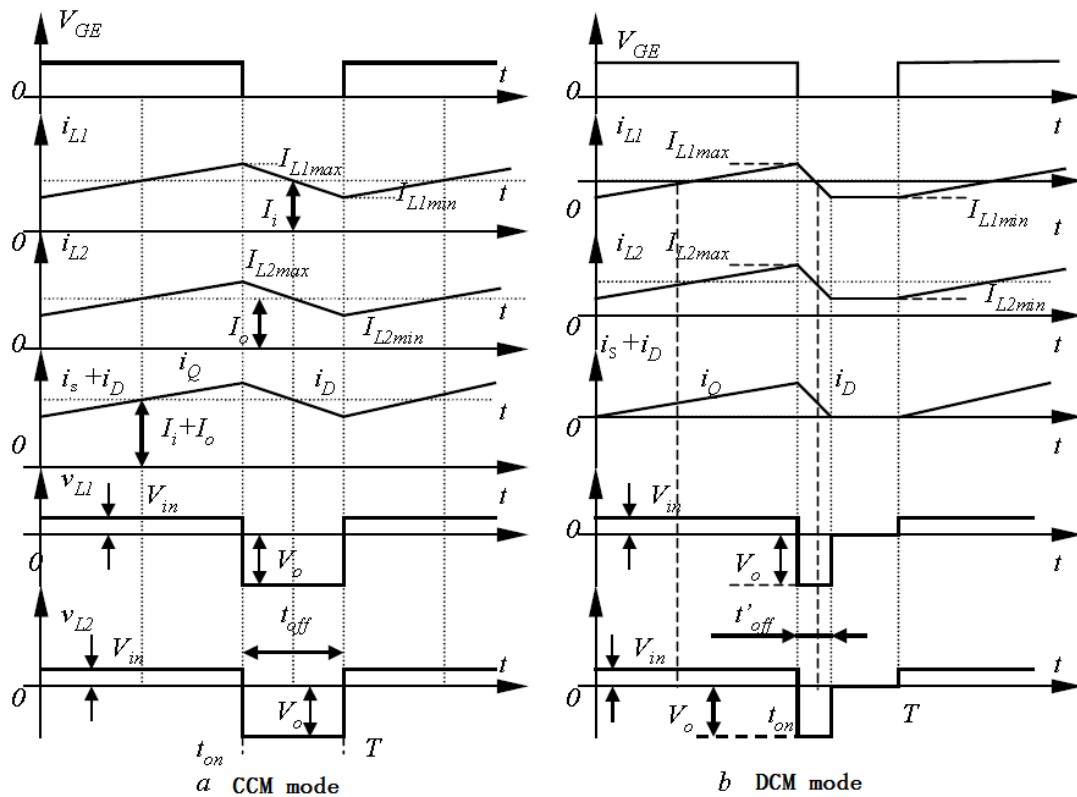

Fig. 2.3.27 Operating waveforms of Cuk converter

**State 1:** Before S on ( $t < 0$ )

The voltage at left of conductor  $C_1$  is  $V_{C1}$ , the voltage equals to earth potential due to the clamping diode D at right.

**State 2:** S on ( $0 \leq t \leq t_{on}$ )

During this period, S conduction, the equivalent circuit is shown in Fig. 2.3.26b. The inductor  $L_1$  charges energy, the capacitor voltage on the capacitor  $C_1$  can not be change suddenly, it makes D reverse bias and the voltage on the left of  $L_2$  is  $-V_{C1}$ , and then  $C_1$  transmits energy through the load Z and  $L_2$ , the load obtains a reverse polarity voltage,  $L_2$  and  $C_2$  begin to store energy. In this circuit configuration, S and diodes D are synchronized to work, S conduction, D cutoff; S off, D conduction. During the  $t_{on}$ , the current of  $L_1$  rises linearly with the rate  $V_i/L_1$ , the current increment is:

$$\Delta i_{l1(+)} = \frac{V_i}{L_1} t_{on} = \frac{V_i}{L_1} \delta T \quad (2.3.28)$$

And current increment of  $L_2$  is:

$$\Delta i_{l2(+)} = \frac{V_{c1} - V_o}{L_2} t_{on} = \frac{V_{c1} - V_o}{L_2} \delta T \quad (2.3.29)$$

**State 3: S off** ( $t_{on} \leq t \leq T$ )

During the period  $t_{off}$ , S cutoff, the equivalent circuit is shown in Fig. 2.3.26c. D is turned on, capacitor  $C_1$  is charged,  $L_1$  charge energy to  $C_1$  through D. At the same time  $L_2$  release energy to the load, in this circuit configuration, no matter in the  $t_{on}$  period or in the  $t_{off}$  period, the input terminal will transmit energy to the load. As long as the inductor  $L_1$ ,  $L_2$  and the capacitor  $C_1$  is large enough, input and output current is essentially smooth.  $C_1$  is charged and store energy during the  $t_{off}$  then discharge and transmit energy to load during  $t_{on}$ ,  $C_1$  plays a role during energy transfer.

In this period of  $t_{off}$ ,  $L_1$  releases energy, voltage drops of  $V_i - V_{C1}$ , the current in  $L_1$  decreases linearly at a rate  $(V_i - V_{C1})/L_1$ , the current reduction is:

$$\Delta i_{l1(-)} = \frac{V_i - V_{C1}}{L_1} t_{off} = \frac{V_i - V_{C1}}{L_1} (1 - \delta) T \quad (2.3.30)$$

Voltage of  $L_2$  is  $-V_o$ , The current reduction of  $L_2$  is:

$$\Delta i_{l2(-)} = \frac{-V_o}{L_2} t_{off} = \frac{-V_o}{L_2} (1 - \delta) T \quad (2.3.31)$$

In the steady state, change of inductor current should be equal for  $L_1$ , considering 2.3.28 and 2.3.30 we have:

$$\frac{V_i}{L_1} t_{on} = \frac{V_i - V_{C1}}{L_1} t_{off} \Rightarrow V_{C1} = V_i \left( 1 - \frac{t_{on}}{t_{off}} \right) = \frac{V_i (1 - 2\delta)}{1 - \delta} \quad (2.3.32)$$

For  $L_2$ , we need take into account 2.3.29 and 2.3.31 :

$$\frac{V_{c1} - V_o}{L_2} t_{on} = \frac{-V_o}{L_2} t_{off} \Rightarrow V_{c1} = -\frac{V_o(1-2\delta)}{\delta} \quad (2.3.33)$$

If  $C_1$  is large enough, voltage during  $t_{on}$  and  $t_{off}$  period can be considered approximately constant (only a small changes), so there we have:

$$\frac{V_i(1-2\delta)}{1-\delta} = -\frac{V_o(1-2\delta)}{\delta} \Rightarrow V_o = -\frac{\delta V_i}{1-\delta} \quad (2.3.34)$$

From 2.3.34 We can understand that the output voltage can be less than, or equal to, or greater than the input voltage, it depends on the value of duty cycle.

In general, output voltage of the photovoltaic cell has great fluctuations, and the buck boost converter can only reduce voltage or rise voltage. The solar cells are difficult to completely work at maximum power point for this reason, which results working efficiency of the system decreased. Meanwhile, the input current ripple of the Buck converter is large. If the input terminal works without an energy storage capacitor, it will make the system work in intermittent mode, which results the photovoltaic cell output the current unsteady and can not be in top working condition; Rather the output current ripple of Boost converter is large, and using this instable current to charge the battery is not conducive to the battery's life. The Cuk converter has both boost and buck function, using it in charge controller of the photovoltaic system can better achieve maximum power point tracking and help to improve efficiency of the system. According to this, we often use the Cuk converter as a main circuit of charge controller .

### 2.3.2 Maximum Power Point tracking (MPPT)

Output power of the solar panels is not only linked with light intensity, but also with load current. From V-I curve of the solar cell we can find the existence of a maximum

power point. In order to obtain most energy in sunlight, it is necessary to take measures to make load characteristics of the solar cells can automatically trace changes of the climate conditions. The solar panels Maximum Power Point tracking (MPPT) technology is proposed for this problem. There are currently several common control strategies:

- A. Hill Climbing and perturb and observe (P&O) .
- B. Fuzzy Logic Control .
- C. Fractional Short-Circuit Current .

### 2.3.3 Charge and discharge management

Another function of the controller is to manage charging and discharging of the battery.

Rated voltage	Anti-overcharge voltage	Anti-over discharge voltage
6V	7.2V $\pm$ 0.1v	5.5V $\pm$ 0.1V
12V	14.3V $\pm$ 0.1V	11.0V $\pm$ 0.1V
24V	28.6V $\pm$ 0.1V	22.0 $\pm$ 0.1V

Table 2.3.35 Overcharge, Over-discharge protection voltage

The large-capacity lead-acid battery can be charged with large current in order to fully charge in a limited time during day time. When voltage of the battery's cell reaches limit voltage, it could easily lead to breakage of battery if it still uses a large current to charge. Therefore, when the battery reaches the overcharge voltage, it can be automatically converted into a trickle charge (small current). The general parameters of protection voltage has shown in Table 2.3.35, in generally the over-discharge protection voltage is 90% of the nominal voltage and the overcharge protection voltage is usually 120% of the nominal voltage. The precision of anti-overcharge

control voltage is  $\pm 0.1\text{v}$ .

The working life under different depth of discharge is not the same, in particular deep discharging of the battery can cause permanent damage. In order to protect the battery life, we must avoid deep discharge. When the battery voltage falls below over discharge point, it should promptly cut off load and stop lighting. Once the protection circuit act, we must ensure that the battery does not automatically discharge anymore before no recharging.

The general parameters of battery overcharge, over-discharge protection voltage are shown in Table 2.3.35. When the battery voltage reaches the set value, then change state of the circuit.

!

### **2.3.4 Automatic switch of lamp**

The LED lights automatically turn on in the evening and automatically turns off power supply at dawn or certain time , this is the time control function of the controller.

It should be noted that: In the evening and dawn, the ambient light changes slowly, the brightness still varies during this process . In general, we can add a delay circuit(A few minutes) in the light control circuit. Thus, when the lights turn on or turn off , there will be no flicker phenomenon.

During design of the controller, such as Load Terminal Short-circuit Protection, Anti-Lightning Protection, Battery Reverse Polarity Protection and other technical requirements is also necessary.



## **2.4 LED light**

Most solar LED street light systems choose the high-power white LED as the lighting source now. Compared to other lighting source, it has a remarkable energy saving, low maintenance cost and several advantages, Thus it's very suitable for the public lighting.

### **2.4.1 Principle of LED light**

All LEDs emit light spectra with narrow-band light (almost monochromatic). Heterochromatic light which is required to illuminate environments is obtained by radiation mixing. There are two primary ways to produce white light-emitting diodes. One is to use two or more different color lights and then mix them together to form the white light. For example, the RGB technic which use the three primary colors (red, green, and blue). Hence the method is called as the multi-color white LEDs. This method is particularly interesting in many uses because of the flexibility of mixing different colors. In principle, this mechanism also has higher quantum efficiency in producing white light. Also there are many other types of the multi-color white LEDs: Dichromatic, Trichromatic and Tetrachromatic. Another technic is Phosphor-based LEDs, that means a phosphor material is used to convert monochromatic light from a blue or UV LED to broad-spectrum white light, much in the same way as fluorescent light bulb works.

### **2.4.2 Main parameters**

The V-I characteristic curve of the LED is much like PN junction, We can see from the Fig. 2.4.1, a small voltage change may result in a large change in current. It is

therefore important that LEDs should be connected to constant-current sources. The instable current will shorten the life of the LED and affect the light failure.

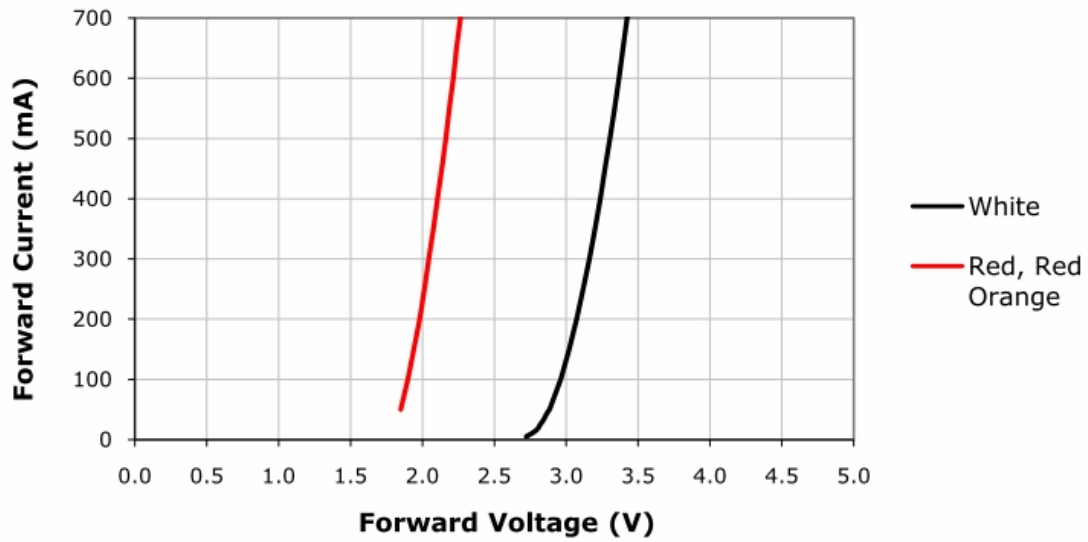

Fig. 2.4.1 Current-voltage graph of LED

The luminous flux is a photometric quantity that measures the perceived power of light. It is adjusted to reflect the various sensitivity of the human eye to different wavelengths of light. The luminous flux is an important indicator of lighting LED and is directly related to the current. As the current increases, the luminous flux of LED's increases too, the relationship between them is shown in Fig. 2.4.2.

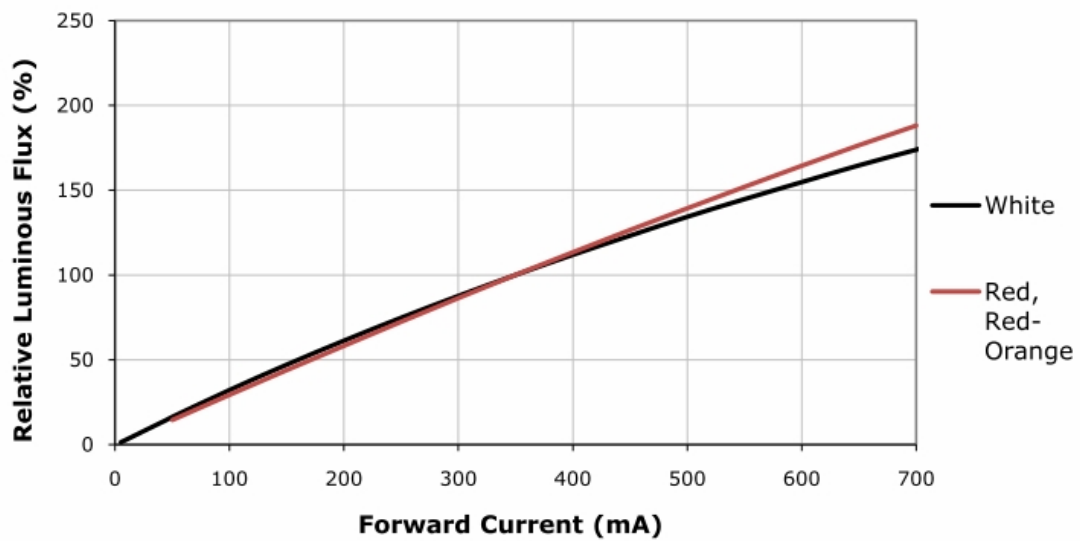

Fig. 2.4.2 Chart of drive current - flux emitted

For this reason it is generally contraindicated to increase the driving current in order to increase the luminous flux, because the loss of efficiency additionally decreases life of the LED.

### 2.4.3 Calculate number of LED

According to the actually lighting requirement on luminous flux and the flux of single LED, we can get the number of LED. Calculation is shown as follows:

$$n_{LED} = \frac{\sum \Phi_v}{\Phi_{vLED}} \frac{1}{\eta_1 \eta_2} \quad (2.4.3)$$

$\sum \Phi_v$ : Objective luminous flux, can be calculated from the illumination requirements.

$\Phi_{vLED}$ : Minimum luminous flux of single LED. (lm)

$\eta_1$ : Optical Efficiency

$\eta_2$ : Thermal efficiency

### 2.4.4 Advantages and disadvantages of white LED

The high-power LED is called as "green light". As the light source for illumination, it has the following advantages:

- \* Long lifetime (35,000 to 50,000 hours of useful life);
- \* Low maintenance costs and replacement costs;
- \* High efficiency;
- \* Clean light (no IR and UV components);
- \* Safety (working in low voltage 3 ~24 V);
- \* Small (smaller than 2 mm) and quickly.

Disadvantages:

- \* Voltage sensitivity (must be supplied with the voltage above the threshold );
- \*Temperature dependence (depends on the ambient temperature );
- \*high costs (\$18/kilolumen by 2010)

# Chapter 3

## Example of system design

### 3.1 Basic meteorological and geographical conditions of Padova

Padova is a sunny moderate-climate city in northern Italy, its coordinates is 45°25'Nord 11°53'Est, the elevation is 18 m a.s.l. The absolute minimum temperature in one year is not lower than -10°C. Upon inquiry, the optimize slope 37° and the optimize azimuth -1° .

The irradiation for each month of the year is shown in Fig. 3.1.1, we can see that the average of daily peak sunshine hours of a year is 4.65h and the minimum amount of irradiation is in December, so our solution ensures that the system can operate normally in December, the average daily irradiation of December is 2320Wh/m<sup>2</sup>/day

Month	$H_{opt}$	$H(37)$
Jan	2290	2290
Feb	3800	3800
Mar	4790	4790
Apr	5520	5520
May	6240	6240
Jun	6270	6270
Jul	6710	6710
Aug	6190	6190
Sep	5390	5390
Oct	3730	3730
Nov	2510	2510
Dec	2320	2320
<b>Year</b>	4650	4650

$H_{opt}$ : Irradiation on optimally inclined plane (Wh/m<sup>2</sup>/day)

$H(37)$ : Irradiation on plane at angle: 37deg. (Wh/m<sup>2</sup>/day)

Fig. 3.1.1 The monthly average of irradiation in a year

### 3.2 technical application of an example

The objective luminous flux of a section of a road in Padova is 8000 lm, the street

light working time per day is 8 hours, it must satisfy the lighting needs of 7 continuous rainy days.

We can select o-ldf100/o-ldy100 as a suitable model form Fig. 3.2.1.

Model	O-LDF60 LDY60	O- LDY80	O-LDF80 LDY80	O- LDY100	O-LDF100 LDY100	O- LDY120	O-LDF120 LDY120	O- LDY150	O-LDF150 LDY150	O- LDY160	O-LDF160 LDY160
LED power dissipation	50W		69W		88W		104W		126W		139W
Lamp Power dissipation	59W		79W		100W		118W		143W		158W
Luminous flux	4850Lm		6624Lm		9080Lm		10800Lm		13000Lm		14320Lm

LDF: Quadratic form  
LDY: Circular form

Fig. 3.2.1 Product Type of Guangzhou O-energy Solar Technology Ltd

The consumption power of the lamp is 100w, it uses NS6L183bt model led lights of Nichia as a lighting source. This lamp is a basic LED lighting products of Nichia company, it has high cost performance ratio. Its data as follows:

### 1) Absolute maximum ratings

Item	Symbol	Absolute Maximum Rating	Unit
Forward Current	$I_F$	800	mA
Pulse Forward Current	$I_{FP}$	900	mA
Allowable Reverse Current	$I_R$	85	mA
Power Dissipation	$P_D$	2.88	W
Operating Temperature	$T_{opr}$	-40~100	°C
Storage Temperature	$T_{stg}$	-40~100	°C
Junction Temperature	$T_J$	135	°C

\* Absolute Maximum Ratings at  $T_S=25^\circ\text{C}$ .

\*  $I_{FP}$  conditions with pulse width  $\leq 10\text{ms}$  and duty cycle  $\leq 10\%$ .

### 2) Initial electrical /optical characteristics

Item	Symbol	Condition	Typ	Max	Unit
Forward Voltage	$V_F$	$I_F=350\text{mA}$	3	-	V
R8000	Luminous Flux	$\Phi_v$ $I_F=350\text{mA}$	105	-	lm
	Luminous Intensity	$I_v$ $I_F=350\text{mA}$	35	-	cd
	Color Rendering	$R_a$ $I_F=350\text{mA}$	85	-	-
Chromaticity Coordinate	x	- $I_F=350\text{mA}$	0.41	-	-
	y	- $I_F=350\text{mA}$	0.39	-	-
Thermal Resistance	$R_{\theta JS}$	-	6	9	°C/W

\* Characteristics at  $T_S=25^\circ\text{C}$ .

\* Luminous Flux value is traceable to the CIE 127:2007-compliant national standards.

\* The Chromaticity Coordinates are derived from the CIE 1931 Chromaticity Diagram.

\*  $R_{\theta JS}$  is Thermal Resistance from junction to  $T_S$  measuring point.

The number of led light can be obtained according to the formula 2.4.3:

$$n_{led} = \frac{9080}{105 * 2.88} \cong 30$$

Then we can calculate the battery. For this system, we choose the Battery LC-P1275 of Panasonic as an example.



## LC-P1275

For standby power supplies  
Expected trickle life: 6 years at 25°C  
10 years at 20°C

### ■ Characteristics

Capacity (25 °C)	20 hour rate	75Ah
	10 hour rate	70Ah
	3 hour rate	53Ah
	1 hour rate	50Ah
Internal Resistance (25 °C)	Fully charged battery	7 mΩ
Temperature Dependency of Capacity (20 hour rate)	40 °C	102%
	25 °C	100%
	0 °C	85%
	-15 °C	65%
Self Discharge (25 °C)	After 3 months	91%
	After 6 months	82%
	After 12 months	64%

For a 24V battery system, current  $I=100W/24V=4.17A$ , then we can get the capacity (C) for 7 continuous rainy days (D) and 8h working time per day (T).

$$C = I * T * (D + 1) = 4.17 * 8 * (7 + 1) = 266.9Ah$$

According to the battery specification, make the total battery system capacity  $C=300Ah$ , the load voltage is 24V, the specification of LC-P1275 Maintenance-free lead-acid batteries is 12V/75Ah. So we can get that:

$$\text{Required number of batteries in series } N_1 = 24V/12V = 2$$

$$\text{Required number of batteries in parallel } N_2 = 480/120 * 2 = 2$$

$$\text{The number of 12V75Ah battery required by street light system is } N = N_1N_2 = 4$$

At last, we calculate the peak demand of solar panel. Usually the solar panel voltage is about 1.5 times of the battery voltage, i.e.  $24V*1.5=36V$ . The street light need 8 hours cumulative lighting time and the average of daily peak sunshine hours is 4.65h.

$$\text{According this, the peak demand of solar panel } W_{(pv)} = \frac{4.17A * 36V * 8h}{4.65h} \cong 258.3W$$

We can use two pieces of 150w solar panels to make some margin.

In addition, there is line loss, power consumptions of the controller, etc. So in practical applications may have about 5% -25% difference, and 258.3W is only a theoretical value.

### 3.3 Comparison with High-pressure sodium(HPS)

The High-Pressure Sodium(HPS) is a positional light source, glows with 360 degrees. Actually the percent of the light which applied to the useful irradiation direction is

about 30%. Therefore, the HPS lamp must reflect the non-useful-irradiation direction light with a reflector to achieve high utilization efficiency. Due lighting design and reflection issues, the efficiency of HPS lamp is only 40-45%.

The LED is focused on the emitting light in concentrate direction, this achieve a high utilization efficiency more than 80%.



Fig. 3.2.1 HPS and LED

Herein we use 100W LED and 250W high pressure sodium lamp as a comparison example.

1) The initial luminous flux of 100W LED lamps is 11000lm. 10% loss because of the lens, 10% loss because of the driver ,the actually luminous flux of lamp is 8910lm, the total consumption power of Lamp is 110W. Therefore, the efficiency of LED street light is 81lm / W.

2) The initial luminous flux of 250W HPS lamps is 25000lm. 30% loss because of light use,20% loss because the power supply, 10% loss because of such as reflector etc. So the actually luminous flux of lamp is 12600lm. The total consumption power of Lamp is about 300w. So the efficiency of HPS street light is 42lm / W.

We have get the final value of luminous efficiency through the analysis and comparison above. The luminous efficiency of 100w LED is almost 2 times of the efficiency of HPS. This is the reasons that we can use 100W LED lamps to replace 250W HPS.



## **Conclusion**

Currently, the initial investment in solar LED street light system remains a major problem. However, the efficiency of the solar cells is increasing, while the price is decreasing. At same time, the efficiency of the LED light is in a rapid increase, but the prices are lower. So following development of the outdoor lighting technic, the solar LED street light system has shown us it will have promising application and infinite vitality.

## **Acknowledgment**

This paper is completed under the guidance of my mentor paolo tenti. I sincerely thank his patient and help. Thanks to all the scholars involved in my paper, without their study and resources I can hardly finish my writing. Also, I want to thank my classmates and friends, they help me a lot during the typesetting process of my writing. Finally my sincere thanks to my parents, their dedication and support make me complete my study successfully. I hope all of you healthy and happy.

## References

- [1] Daniel F. Butay, Michael T. Miller. "Maximum Peak Power Tracker: A Solar Application" April 24th, 2008.
- [2] "Lab 1 – Electrical Characteristics of Photovoltaic Cells " School of Electrical and Information Engineering, University of Sydney. Semester 2, 2011.
- [3] Pan Shiquan "Application Research in the Solar Street Lamp Management Based on the LED Light-emitting Diodes" Bulletin of Science and Technology, Vol.28 No.4 Apr.2012.
- [4] P. Tenti. "Dispense del Corso di Elettronica Industriale". Università degli Studi di Padova. 2012
- [5] T. Esum. "Comparison of Photovoltaic Array Maximum Power Point Tracking Techniques" Energy Conversion, IEEE Transactions on(Volume:22 Issue: 2 ). 2007.
- [6] Wang Yongqing. "Design of Solar LED Street Lamp Automatic Control Circuit". National Testing Center of Iron & Steel. 2009
- [7] M. Seraceni. "Illuminazione stradale a LED". First part redux. 2010.
- [8] Photovoltaic Geographical Information System. Available at:  
<http://re.jrc.ec.europa.eu/pvgis/apps4/pvest.php#>
- [9] Solar Angles and Tracking Systems. Available at:  
[http://www.teachengineering.org/view\\_lesson.php?url=collection/cub\\_/lessons/cub\\_pveff/cub\\_pveff\\_lesson01.xml](http://www.teachengineering.org/view_lesson.php?url=collection/cub_/lessons/cub_pveff/cub_pveff_lesson01.xml)

[10] Lead–acid battery. Available at:

[https://en.wikipedia.org/wiki/Lead%E2%80%93acid\\_battery](https://en.wikipedia.org/wiki/Lead%E2%80%93acid_battery)

[11] Rechargeable battery. Available at:

[https://en.wikipedia.org/wiki/Rechargeable\\_battery](https://en.wikipedia.org/wiki/Rechargeable_battery)

[12] Technical Support of America Amercom Power Limited. Available at:

<http://www.amercom.com.cn/Technical.html>

[13] Maximum power point tracking. Available at:

[http://en.wikipedia.org/wiki/Maximum\\_power\\_point\\_tracking](http://en.wikipedia.org/wiki/Maximum_power_point_tracking)

[14] Light-emitting diode. Available at:

[http://en.wikipedia.org/wiki/Light-emitting\\_diode](http://en.wikipedia.org/wiki/Light-emitting_diode)